

SERVICE MANUAL

EG1L(GA) CHASSIS

<u>MODEL</u>	<u>COMMANDER</u>	<u>DEST.</u>
KLV-40V400A	RM-GA011	E, EA, Egypt, India, Iran, ME, Thailand, Phillipines, Saudi Arabia, South Africa, Vietnam
KLV-46V400A	RM-GA011	E, EA, India, Iran, ME, Thailand, Phillipines, Saudi Arabia, South Africa, Vietnam

<u>MODEL</u>	<u>COMMANDER</u>	<u>DEST.</u>
--------------	------------------	--------------



KLV-40V400A



KLV-46V400A



RM-GA011

TABLE OF CONTENTS

<u>Section Title</u>	<u>Page</u>	<u>Section Title</u>	<u>Page</u>
1. SAFETY NOTES		6. DIAGRAMS	
1-1. Caution Handling of LCD Panel	3	6-1. Block Diagram	20
1-2. Safety Check Out	3	6-2. Circuit Board Location	20
1-3. Leakage Test	3	6-3. Schematic Diagram	21
1-4. WARNING !	3	6-4. Printed Wiring Boards	21
1-5. LED Free Information	4	6-5. Semiconductor	21
1-6. Caution	5		
2. SELF DIAGNOSTIC FUNCTION		7. EXPLODED VIEWS	
2-1. Overview of Control Buttons	6	7-1. KLV-40V400A	22
2-2. LED Display Specification	6	7-1-1. Rear Cabinet and Stand Assy	22
2-3. LED Display Control	6	7-1-2. Frame and Cover	23
2-4. LED Pattern	6	7-1-3. Chassis-1	24
2-5. Standby LED Error Displays	7	7-1-4. H3E & H4 Board and Speaker	25
		7-1-5. Bezel Assy and LCD Panel	26
3. DISASSEMBLY		7-2. KLV-46V400A	27
3-1. Rear Cover Removal	8	7-2-1. Rear Cabinet and Stand Assy	27
3-2. Stand Assy Removal	8	7-2-2. Frame and Cover	28
3-3. Switch Unit Removal	8	7-2-3. Chassis-1	29
3-4. BG1 Board Removal	9	7-2-4. H3E & H4 Board and Speaker	30
3-5. IP5 Board Removal	9	7-2-5. Bezel Assy and LCD Panel	31
3-6. Vesa Frame Removal	9		
3-7. H4, H3 and Speaker Removal	10	8. ELECTRICAL PARTS LIST	32
3-8. LCD Panel and Assy Removal	10		
4. WIRE DRESSING			
4-1. KLV-40V400A	11-13		
4-2. KLV-46V400A	14-17		
5. SERVICE ADJUSTMENTS			
5-1. Accessing Diagnostic Menu	18		
5-2. Aging	18		
5-3. Resetting the User Menu- Factory Reset	18		
5-4. White Balance Adjustment	19		
5-5. Board and Panel Replacement	19		

OPERATING INSTRUCTIONS

SECTION 1 SAFETY NOTES

1-1. Caution Handling of LCD Panel

When installing the LCD Panel, make sure you are grounded with a wrist band.
When installing the LCD Panel on the wall, the panel must be secured using the 4 mounting holes on the rear cover.

- 1) Do not press the panel or frame edge to avoid the risk of electric shock.
- 2) Do not scratch or press on the panel with any sharp objects.
- 3) Do not leave the module in high temperature or in areas of high humidity for an extended period of time.
- 4) Do not expose the LCD panel to direct sunlight.
- 5) Avoid contact with water. It may cause short circuit within the module.
- 6) Disconnect the AC adapter when replacing the backlight (CCFL) or inverter circuit. (High voltage occurs at the inverter circuit at 650Vrms)
- 7) Always clean the LCD panel with a soft cloth material.
- 8) Use care when handling the wires or connectors of the inverter circuit. Damaging the wires may cause a short circuit.
- 9) Protect the panel from ESD to avoid damaging the electronic circuit (C-MOS).

1-2. Safety Check-Out

After correcting the original service problem, perform the following safety checks before releasing the set to the customer:-

- 1) Check the area of your repair for unsoldered or poorly soldered connections. Check the entire board surface for solder splashes and bridges.
- 2) Check the interboard wiring to ensure that no wires are "pinched" or contact high-wattage resistors.
- 3) Check all control knobs, shields, covers, ground straps and mounting hardware have been replaced. Be absolutely certain you have replaced all the insulators.
- 4) Look for unauthorized replacement parts, particularly transistors that were installed during a previous repair. Point them out to the customer and recommend their replacement.
- 5) Look for parts which, though functioning show obvious signs of deterioration. Point them out to the customer and recommend their replacement.
- 6) Check the line cords for cracks and abrasion. Recommend the replacement of any such line cord to the customer.
- 7) Check the antenna terminals, metal trim, "metallized" knobs, screws and all other exposed metal parts for AC leakage. Check leakage test as described next.

1-3. Leakage Test

The AC leakage from any exposed metal part to earth ground and from all exposed metal parts to any exposed metal part having a return to chassis must not exceed 0.5mA (500 microamperes). Leakage current can be measured by any one of the three methods:-

1. A commercial leakage tester such as the SIMPSON 229 or RCA WT-540A. Follow the manufacturers instructions to use those instructions.

2. A battery-operated AC milliammeter. The DATA PRECISION 245 digital multimeter is suitable for this job.

3. Measuring the voltage drop across a resistor by means of a VOM or battery operated AC voltmeter. The 'limit' indication is 0.75V so analog meters must have an accurate low voltage scale. The SIMPSON'S 250 and SANWA SH-63TRD are examples of passive VOMs that are suitable. Nearly all battery operated digital multimeters that have a 2 VAC range are suitable. (see FIGURE 1)

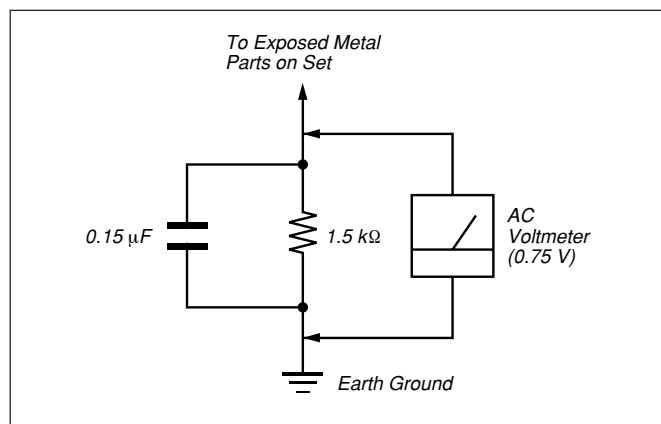

Figure 1. AC voltmeter to check AC leakage

1-4. WARNING !

SAFETY-RELATED COMPONENT WARNING!
COMPONENTS IDENTIFIED BY SHADING AND MARK Δ ON THE EXPLODED VIEWS ARE CRITICAL FOR SAFE OPERATION. REPLACE THESE COMPONENTS WITH SONY PARTS WHOSE PART NUMBERS APPEAR AS SHOWN IN THIS MANUAL OR IN SUPPLEMENTS PUBLISHED BY SONY. CIRCUIT ADJUSTMENTS THAT ARE CRITICAL FOR SAFE OPERATION ARE IDENTIFIED IN THIS MANUAL. FOLLOW THESE PROCEDURES WHENEVER CRITICAL COMPONENTS ARE REPLACED OR IMPROPER OPERATION IS SUSPECTED.

1-5. LED Free Information

The circuit boards used in these models have been processed using Lead Free Solder. The boards are identified by the LF logo located close to the board designation.



Figure 2: LF logo

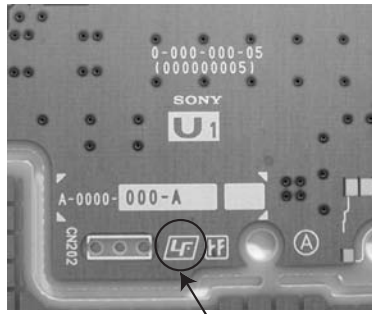

Figure 3: LF logo on circuit board

The servicing of these boards requires special precautions. It is strongly recommended to use Lead Free Solder material in order to guarantee optimal quality of new solder joints. Lead Free Solder is available under the following part numbers:-

Part number	Diameter	Remarks
7-640-005-19	0.3mm	0.25Kg
7-640-005-20	0.4mm	0.50Kg
7-640-005-21	0.5mm	0.50Kg
7-640-005-22	0.6mm	0.25Kg
7-640-005-23	0.8mm	1.00Kg
7-640-005-24	1.0mm	1.00Kg
7-640-005-25	1.2mm	1.00Kg
7-640-005-26	1.6mm	1.00Kg

Due to high melting point of Lead Free Solder, the soldering iron tip temperature needs to be set to 370 degrees centigrade. This requires soldering equipment capable of accurate temperature control coupled with a good heat recovery characteristics.

For more information on the use of Lead Free Solder, please refer to <http://www.sony-training.com>

1-6. Caution

CAUTION

Attachment of HIROSE MDF 61 connector

1. Insertion

(1) Hold the center of a connector



(2) Press the center of the connector to insert it



(3) Slide the slider to lock the connector

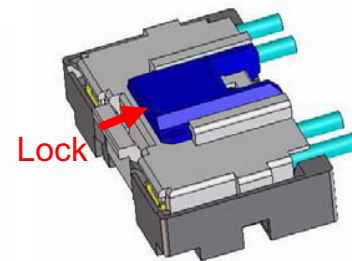
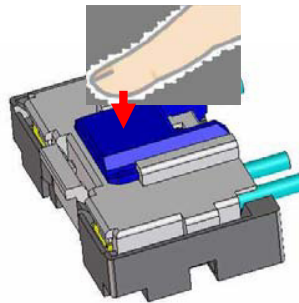
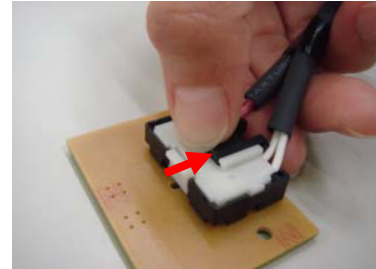
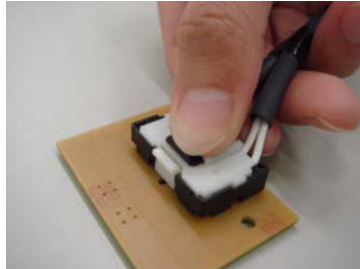
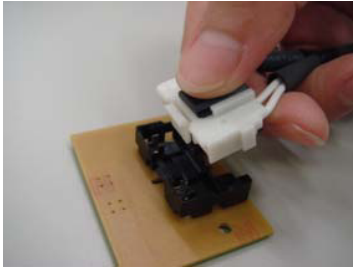

Detachment of HIROSE MDF61 connector

2. Detachment

(1) Slide the slider to release the slider lock



(2) Press the center lock tab to release the lock and pull the connector up

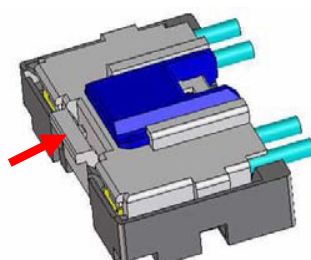
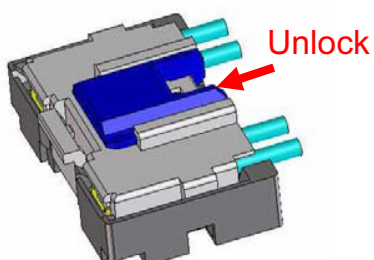
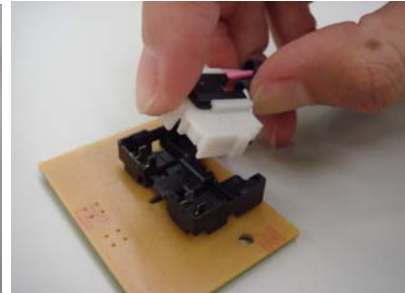
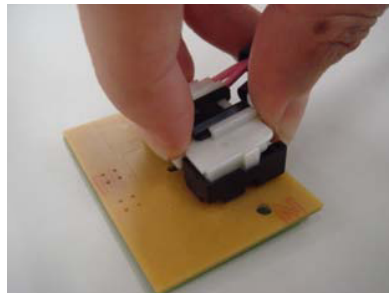
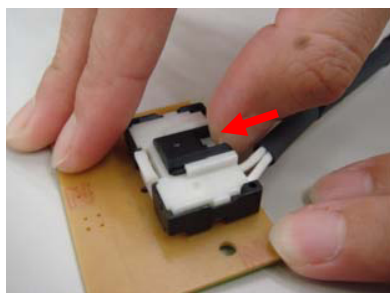

SECTION 2 SELF DIAGNOSTIC FUNCTION

2-1. Overview of Control Buttons

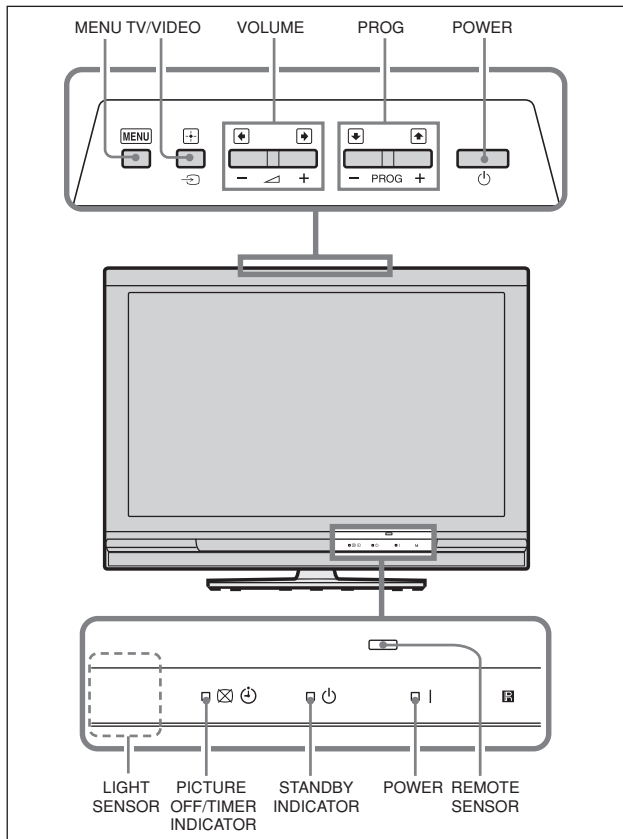

2-4. LED Pattern

When safety shutdown occurs, Standby LED display reports the cause by using the lightning patterns as indicated below.

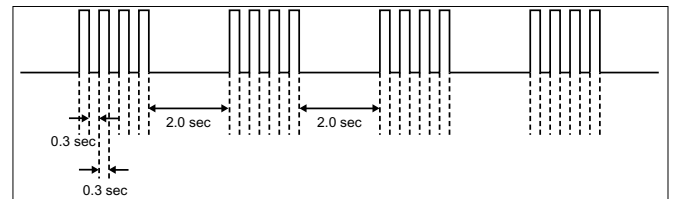

Example:

The figure above shows LED display when SHUTDOWN is caused by DC_ALERT 2. It repeats flashing for a specified number of times in 0.3sec/cycle and has a 2 seconds interval of lighting off. Please note that a 2 seconds interval of lighting off is fixed regardless of abnormal state types.

2-2. LED Display Specification

LED Type	Description	Remark
POWER	Green: LED	Green lights at power ON.
STANDBY	Red: One LED	Red lights during standby.
Picture Off/Timer	Green/Amber : Two LEDs	Green lights during Picture OFF and amber lights during Timer activation.

2-3. LED Display Control

Status	Display		Remark
	Power LED	Standby LED	
POWER ON	Green lights	OFF	Microcomputer is in a normal state.
STANDBY	OFF	Red lights	Microcomputer is in a sleep state.
Failure	OFF	Red flashes	Classify the trouble causes by the no. of red.

2-5. Standby LED Error Display

Perform below countermeasures according to Standby LED blinking times.

Blinking times	Error	Countermeasure
2	DC_DET (12V Main Voltage)	Replace either/both ● BG1 board ● IP5 board
3	DC_ALERT 1	Replace BG1 board.
4	DC_ALERT 2	Replace BG1 board.
5	DC_ALERT 3	Replace BG1 board.
6	BACKLIGHT/ INVERTER ERROR	Replace BG1 board.
7	INTERNAL TEMP ERROR	Replace IP5 board
8	AUDIO ERROR	Replace either/both ● BG1 board ● IP5 board ● Speaker
9	Not used for GA	—
10	Not used for GA	—
11	NVM ERROR	Replace either/both ● BG1 board ● IP5 board
12	IIC ERROR	Replace BG1 board.
13	BALANCER ERROR	Replace BG1 board.
14	HDMI ERROR	—

Note: Each of the above blinking repeats every 2 seconds.

SECTION 3 DISASSEMBLY

3-1. Rear Cover Removal

(KLV-40V400A)

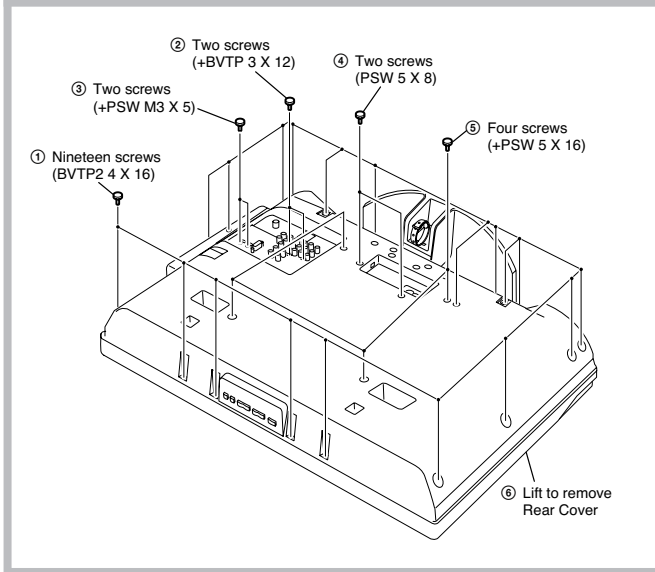

(KLV-46V400A)

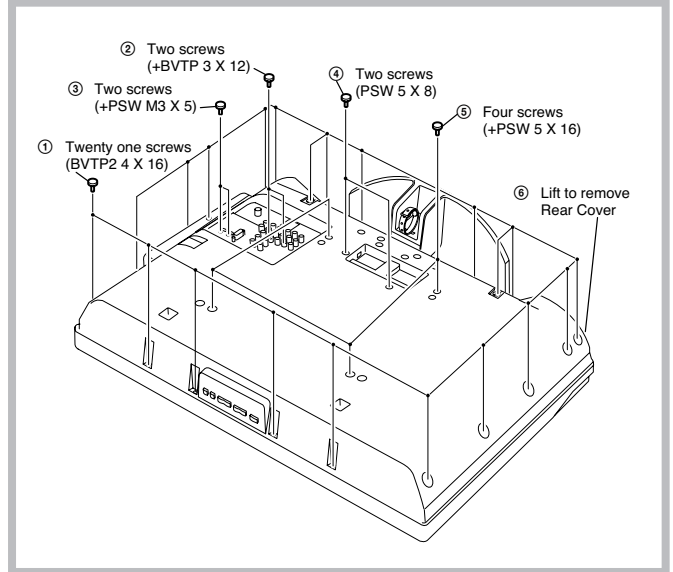

3-2. Stand Assy Removal

(KLV-40V400A)

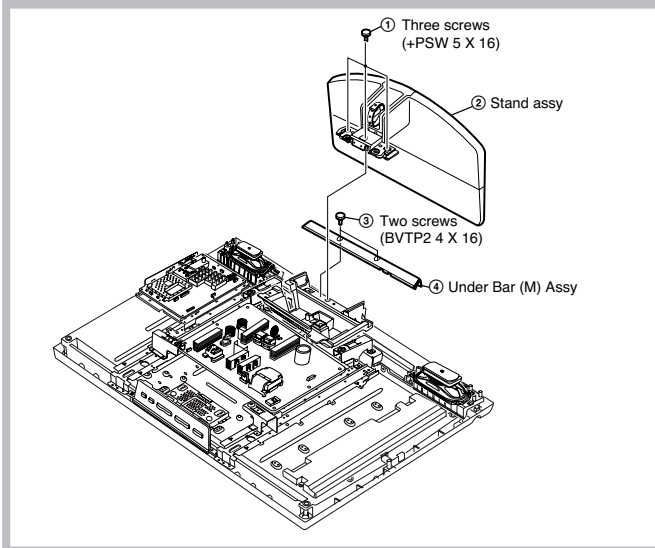

(KLV-46V400A)

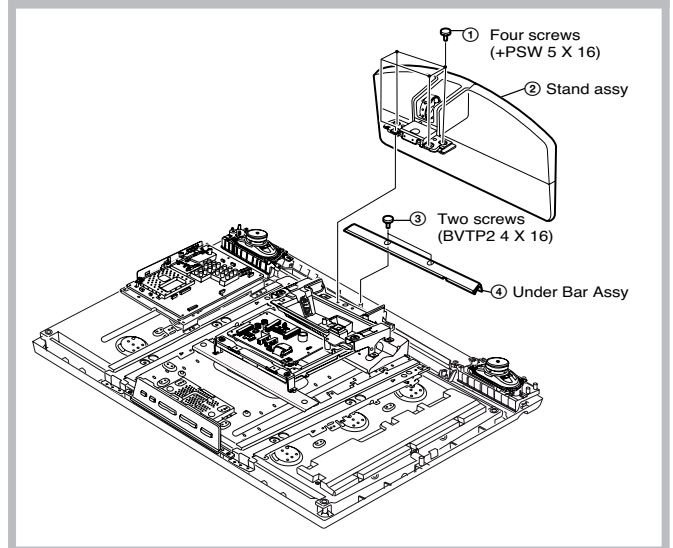

3-3. Switch Unit Removal

(KLV-40V400A)

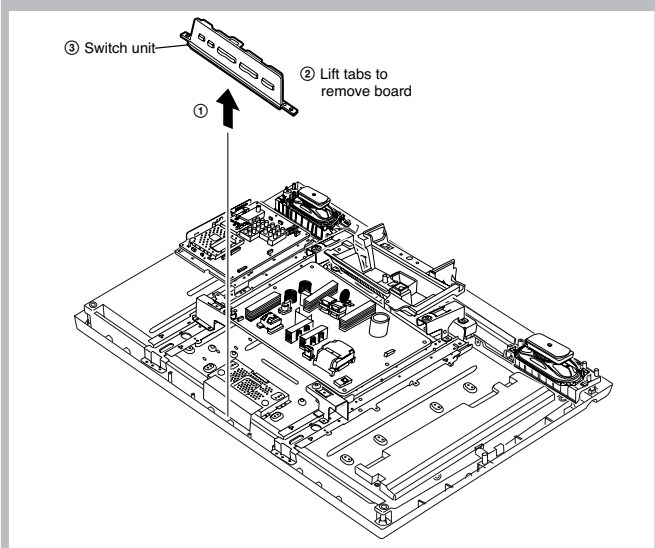

(KLV-46V400A)

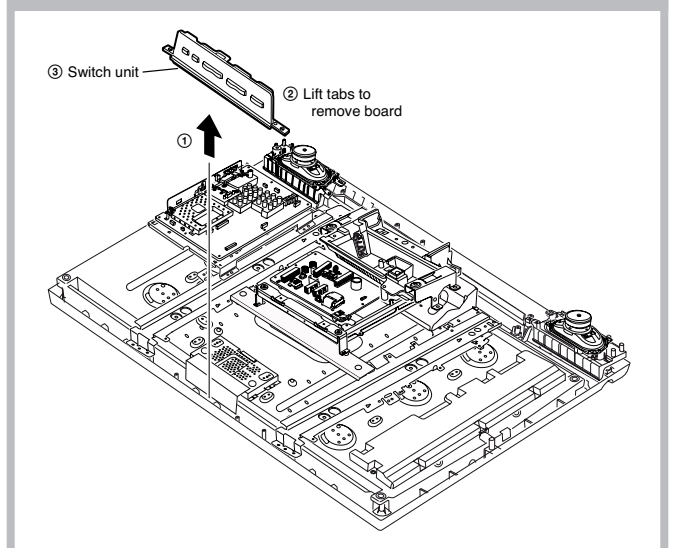

3-4. BG1 Board Removal

(KLV-40V400A)

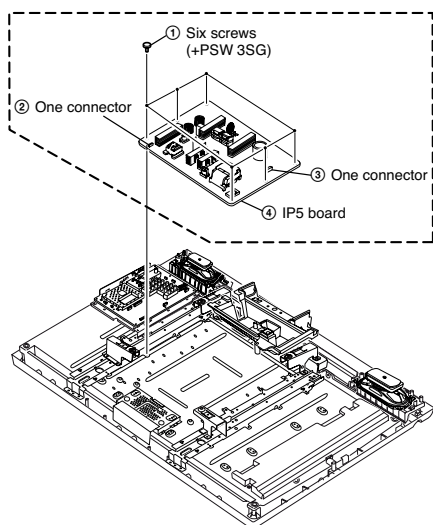

(KLV-46V400A)

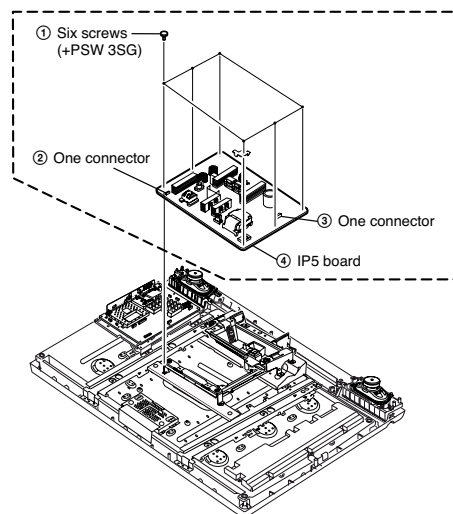

3-5. IP5 Board Removal

(KLV-40V400A)

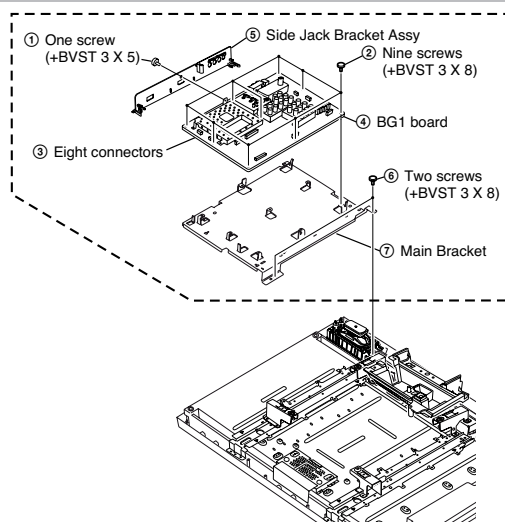

(KLV-46V400A)

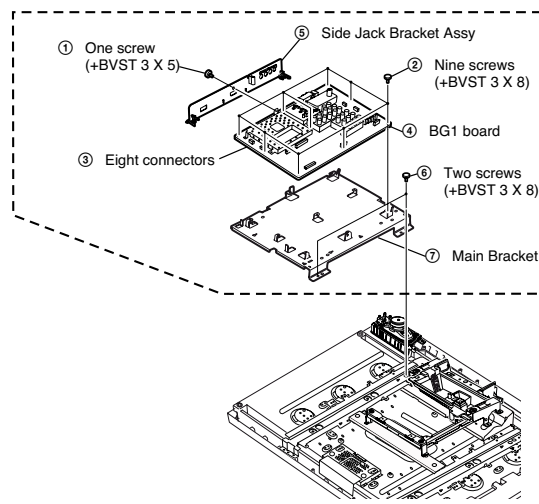

3-6. Vesa Frame Removal

(KLV-40V400A)

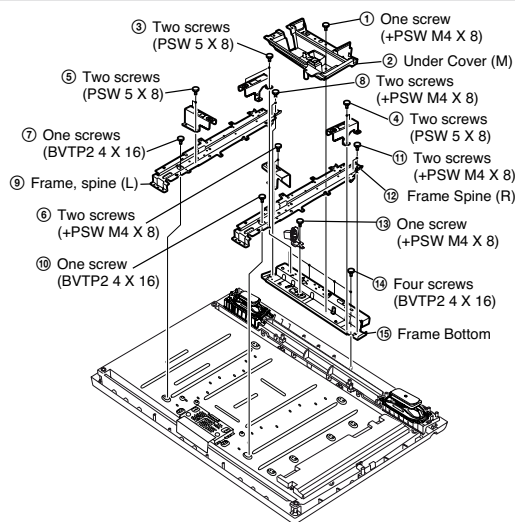

(KLV-46V400A)

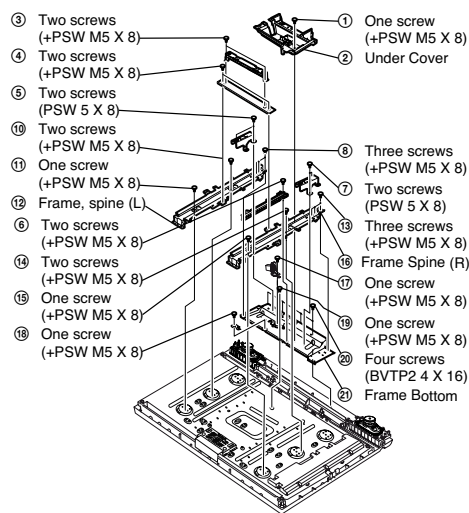

3-7. H4, H3 and Speaker Removal

(KLV-40V400A)

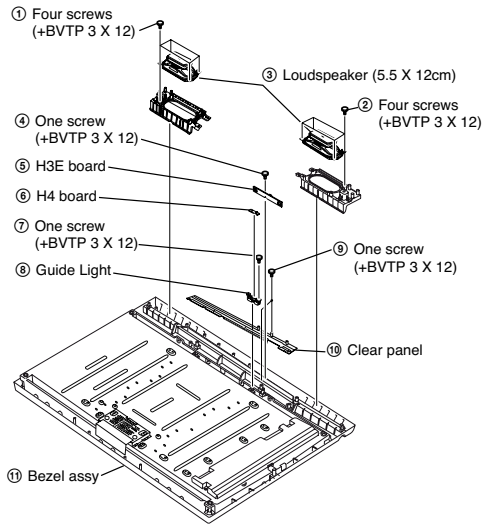

(KLV-46V400A)

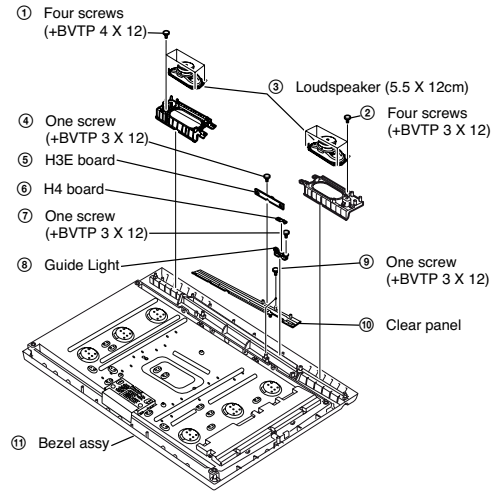

3-8. LCD Panel and Bezel Assy Removal

(KLV-40V400A)

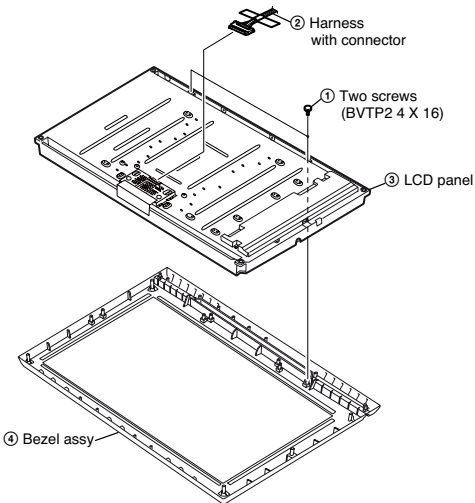

(KLV-46V400A)

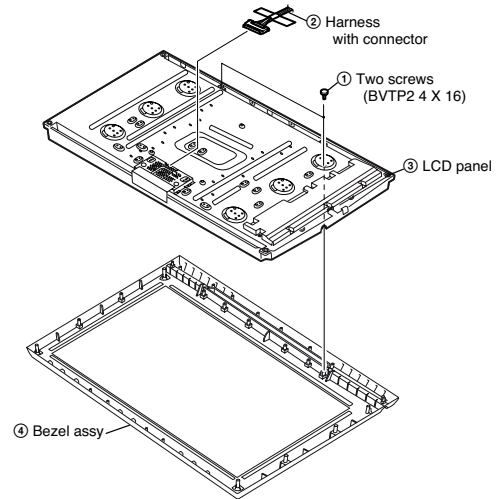

SECTION 4 WIRE DRESSING

CAUTION :

1. Do not overpull the wires during dressing --> avoid disconnection of wires.
2. Make sure wires are kept away from sharp edges, heatsinks & other high-temperature parts.

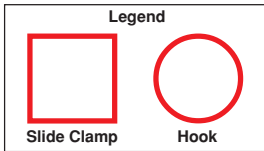

4-1.(KLV-40V400A)

4-1-1. Wire dressing overview

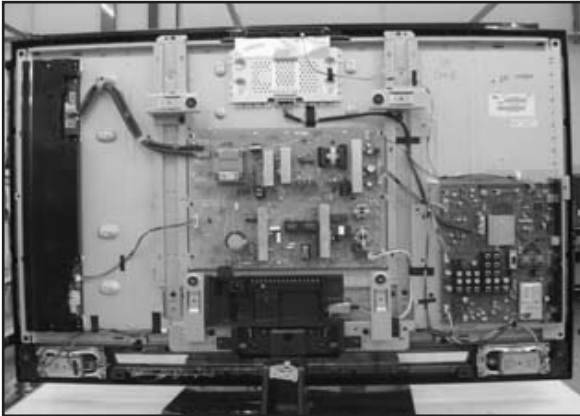

4-1-2. Dress LVDS cable with Sheet Core C & Shield Tape as shown

Make sure LVDS connector fully inserted with correct direction as shown.

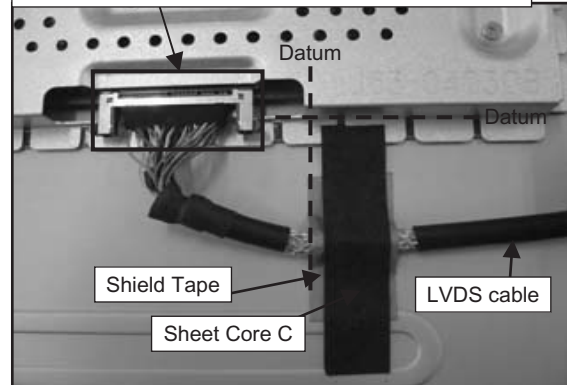

4-1-3. Dress LVDS cable with Sheet Core C on spine frame as shown

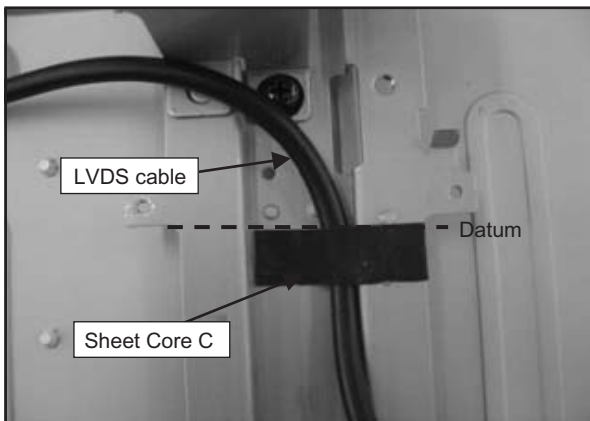

4-1-4. Screw LVDS cable's clamp on main bracket as shown

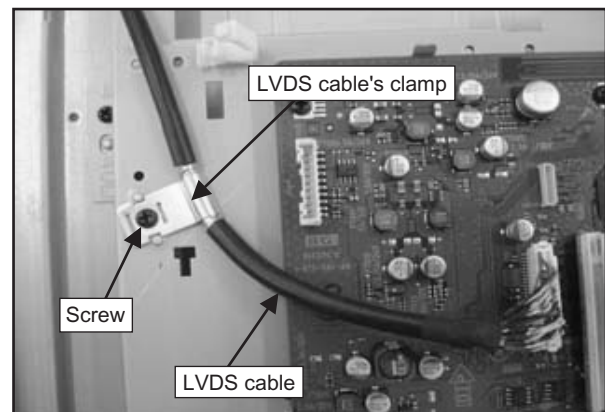

4-1-5. Dress Connector Assy 14P+20P & Speaker Wire with sheet core C(2X) as shown

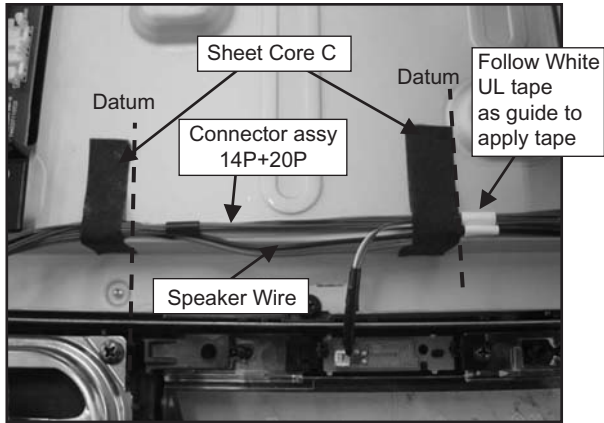

4-1-6. Dress Connector Assy 14P+20P & Speaker wire with sheet core C(3X) as shown.

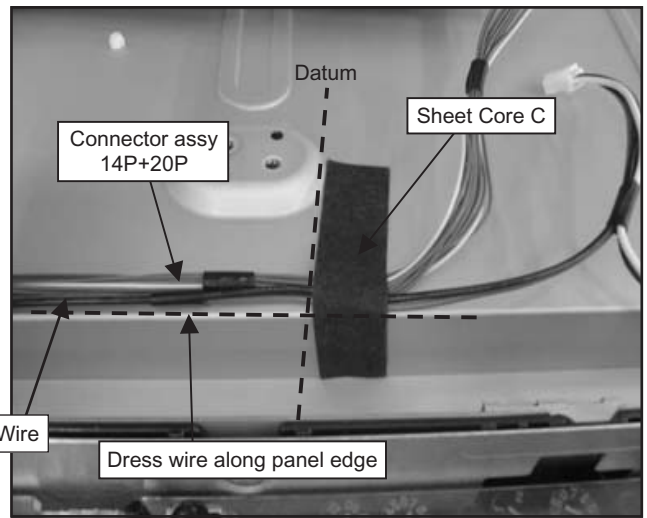
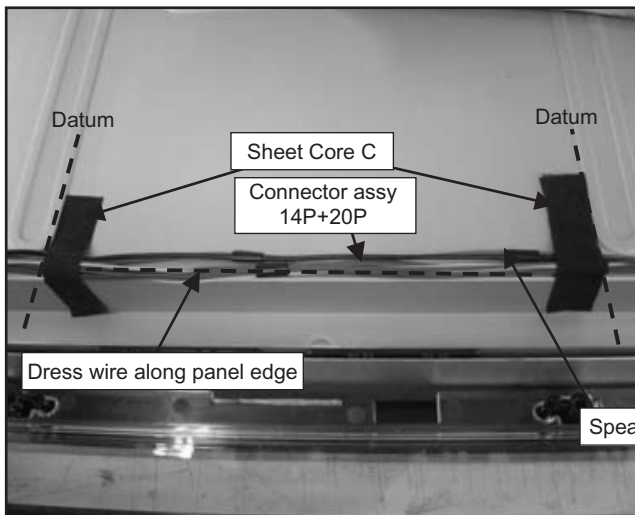

**4-1-7. 1) Connector Assy 40P+20P
2) Dress Connector Assy 14P+20P with slide clamp(2X) as shown.**

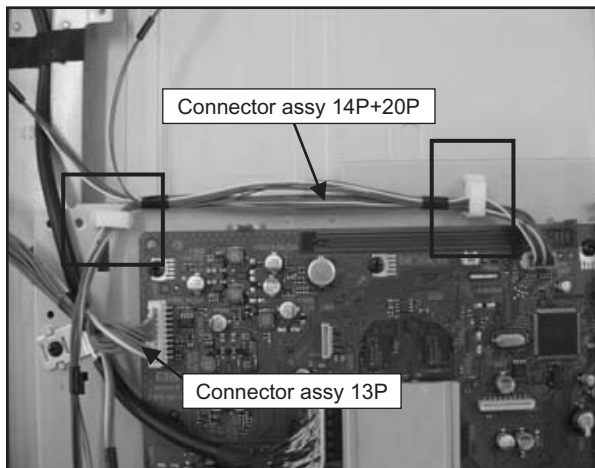

**4-1-8. 1) Dress Connector Assy 14P+20P on top of Connector Assy 13P as shown.
2) Dress Connector Assy 14P+20P with LCD tape as shown.**

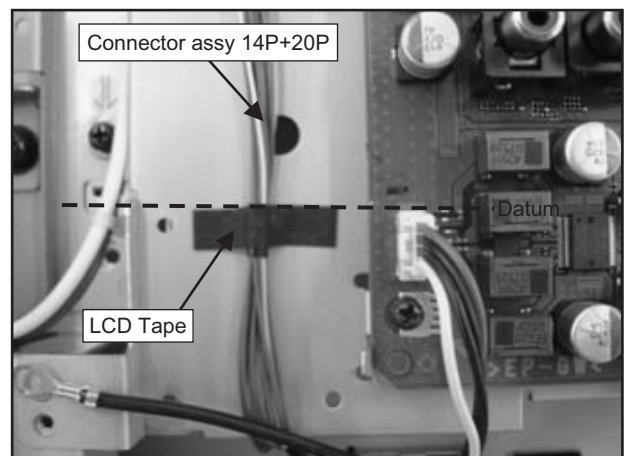

- 4-1-9. 1) Ground Wire and Speaker Wire
2) Screw Ground wire and dress underneath speaker wire as shown.

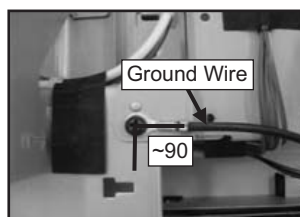
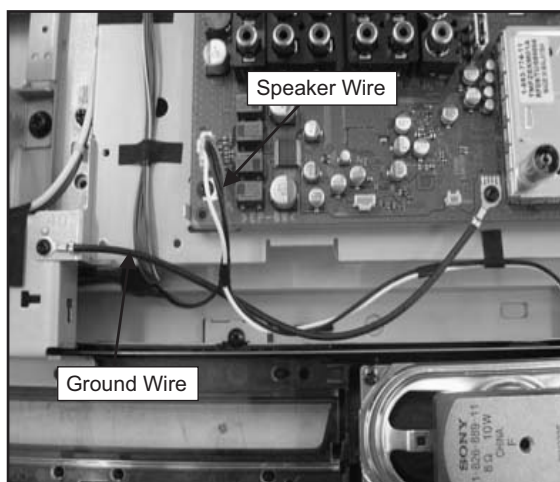

4-6-2. Dress speaker wire with LCD tape as shown

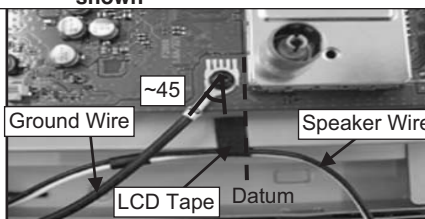

- 4-1-10. 1) Inverter Wire and Connector Assy 7P
2) Dress Inverter wire with clamp(2X) as shown.

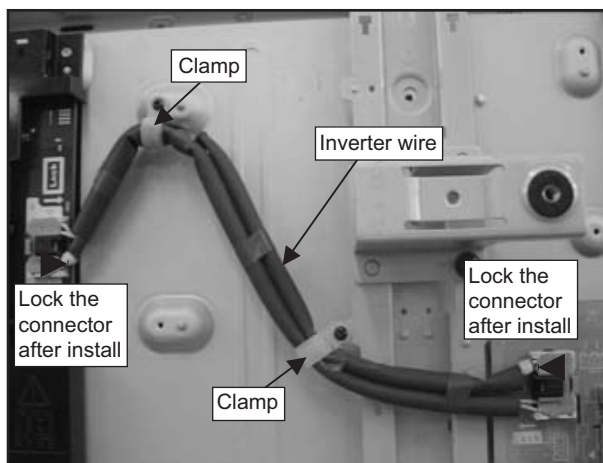

- 4-1-11. 1) Dress Connector assy 7P with LCD tape as shown.

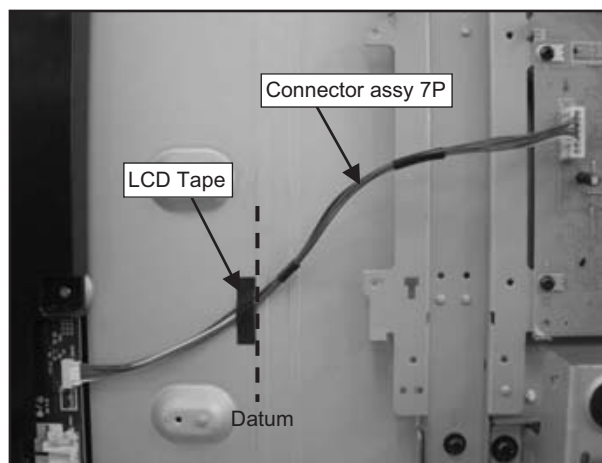

- 4-1-12. 1) AC Inlet Wire and Connector Assy 14P+20P
2) Dress AC Inlet wire with Sheet Core C(2X) as shown.

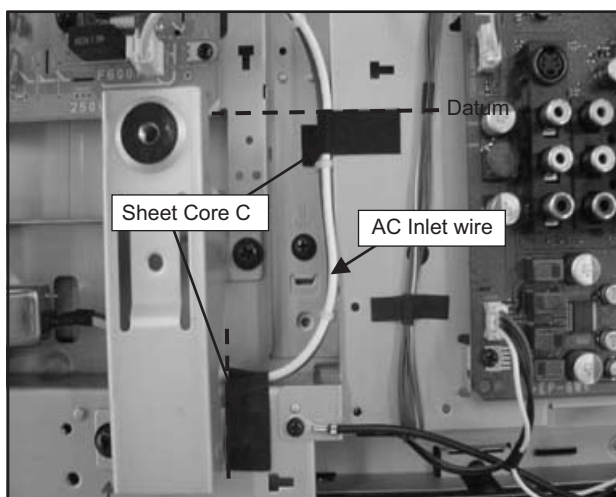

- 4-1-13. 1) Dress Connector assy 14P+20P with LCD tape(2X) as shown.

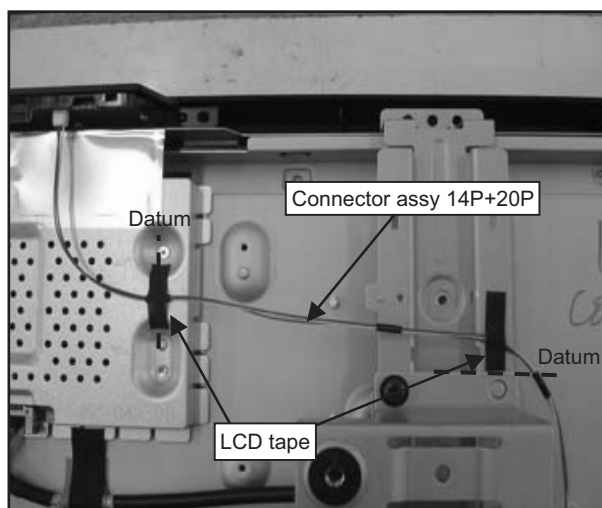

4-2.(KLV-46V400A)

4-2-1. OVERALL VIEW

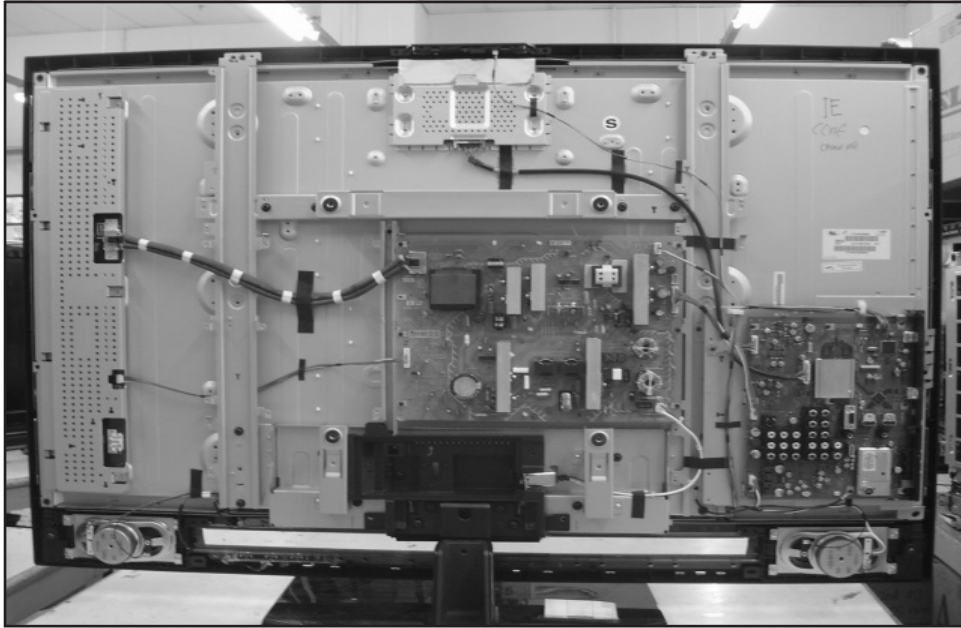

4-2-2. Dress LVDS

- 1) Dress LVDS cable with Sheet Core C(2X) & Shield Tape as shown in figure A.
- 2) Dress LVDS cable with Sheet Core C on spine frame as shown in figure B.
- 3) Screw LVDS cable's clamp on main bracket as shown in figure C.

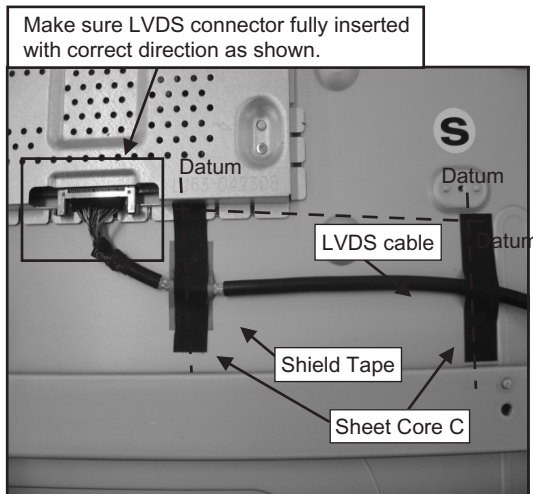

Figure A

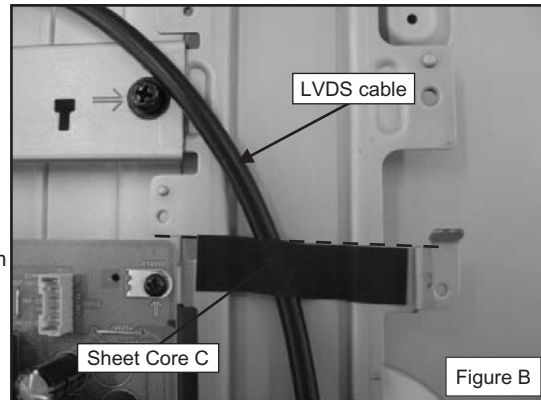

Figure B

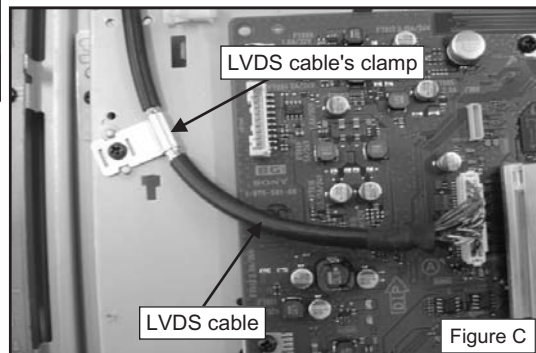
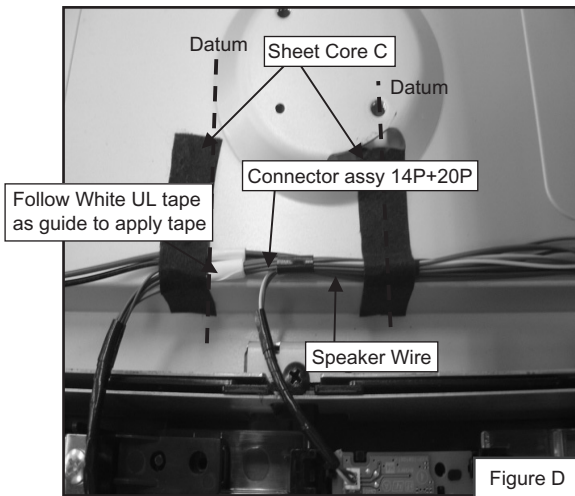

Figure C

4-2-3. Dress Connector Assy

Dress Connector Assy 14P+20P & Speaker Wire with sheet core C(2X) as shown in figure D.



4-2-4. Dress Connector Assy

Dress Connector Assy 14P+20P & Speaker wire with sheet core C(4X) as shown in figure E & F.

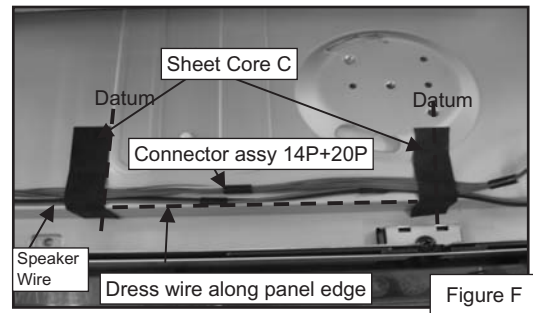
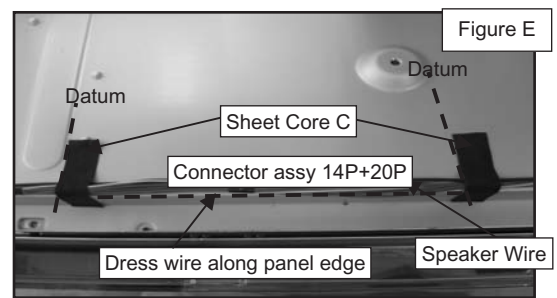

4-2-5. Dress Connector Assy

- 1) Dress Connector Assy 14P+20P with slide clamp(2X) as shown in figure G.
- 2) Dress Connector Assy 14P+20P on top of Connector Assy 13P as shown in figure G.
- 3) Dress Connector Assy 14P+20P with LCD tape as shown in figure H.

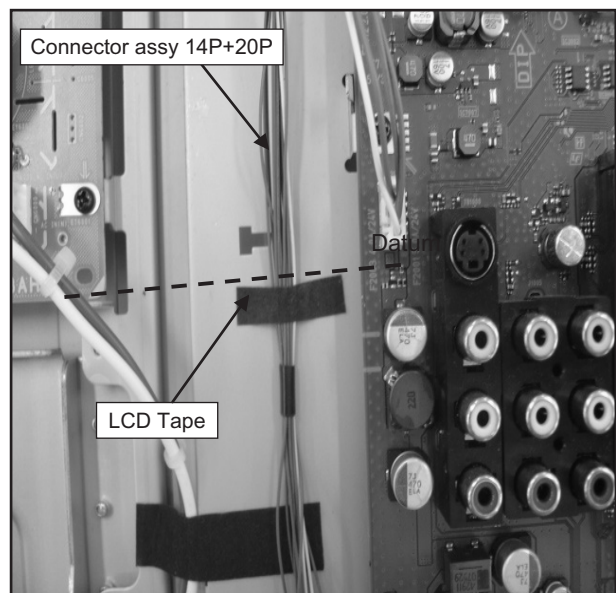
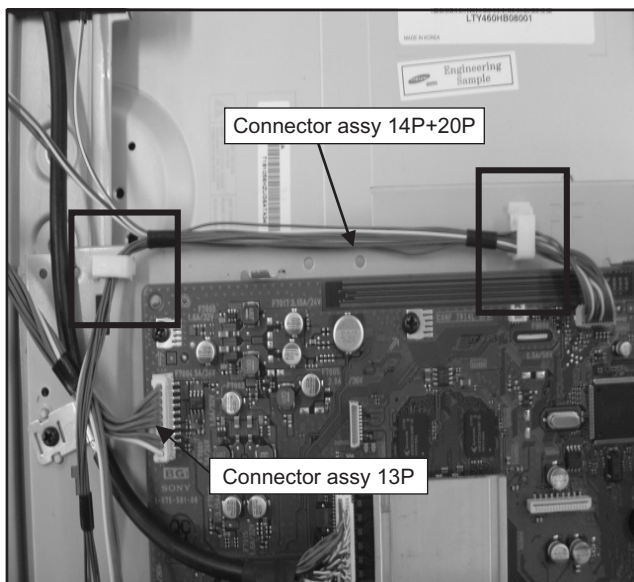

4-2-6. Speaker Wire

- 1) Screw Ground wire and dress underneath speaker wire as shown in figure I,J&K.
- 2) Dress speaker wire with LCD tape as shown in figure K.

Figure J

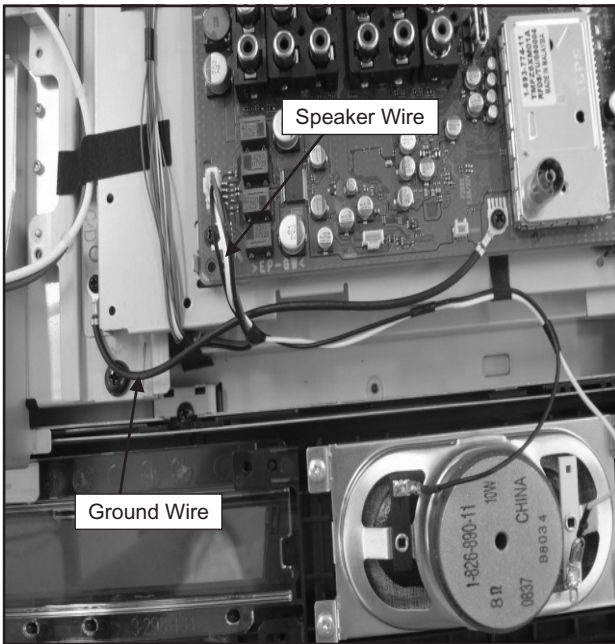

Figure I

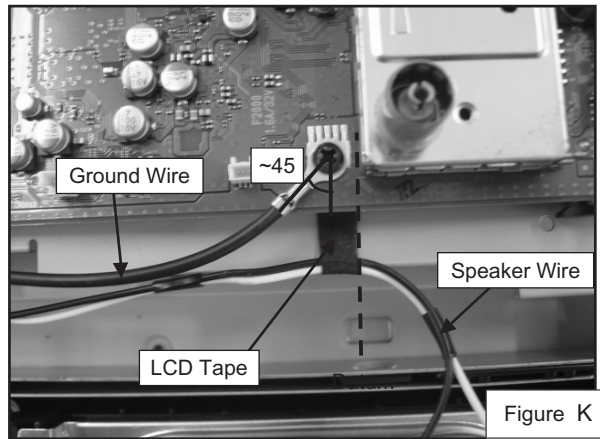
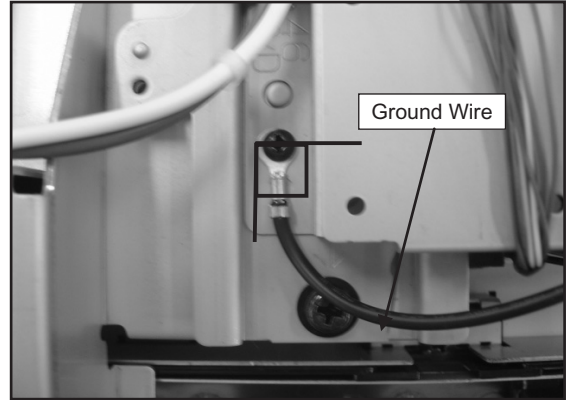

Figure K

4-2-7. Connector Assy at Speaker Bracket

Dress Connector assy 14P+20P at speaker bracket's hook as shown in figure L&M.

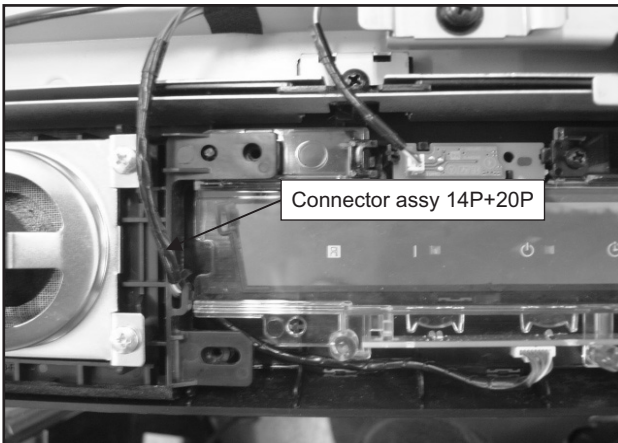

Figure L

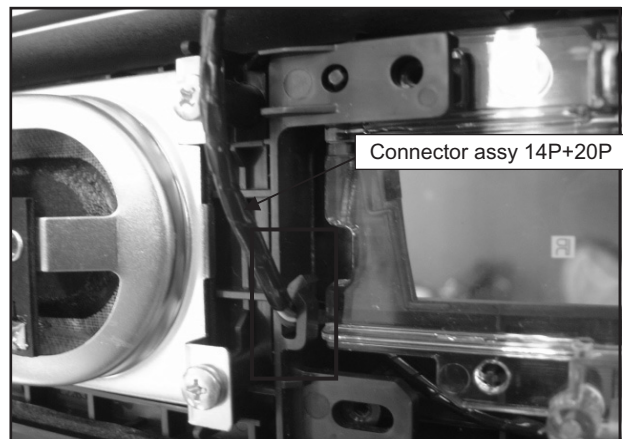
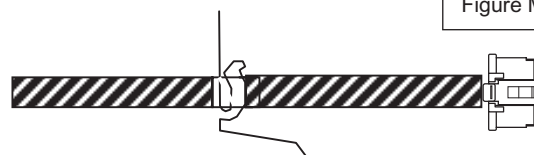

Figure M



Dress H3E connector assy with speaker bracket's hook at the area without UL tape

4-2-8. Dress Inverter Wire and Dress Connector Assy

- 1) Dress inverter wire with Sheet Core E as shown in figure N.
- 2) Dress Connector assy 7P with LCD tape as shown in figure O

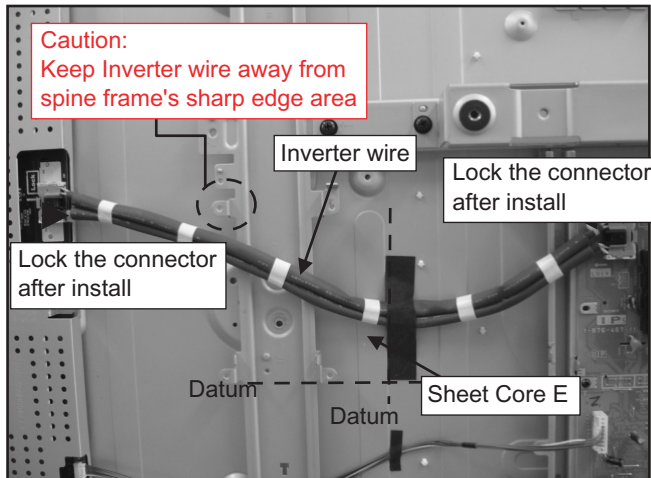

Figure N

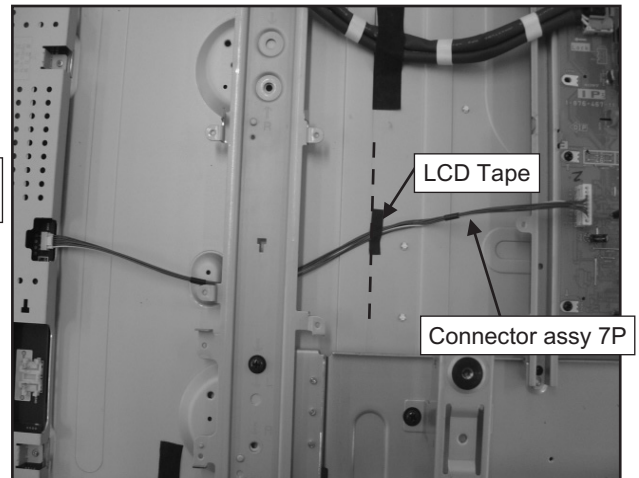

Figure O

4-2-9. Dress AC Inlet Wire and Dress Connector Assy

- 1) Dress AC inlet wire with Sheet Core C(2X) as shown in figure P.
- 2) Dress Connector assy 14P+20P with LCD tape(2X) as shown in figure Q.

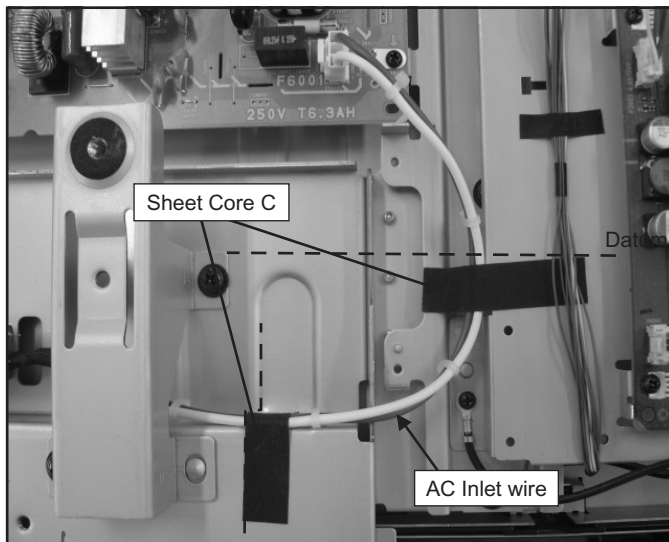

Figure P

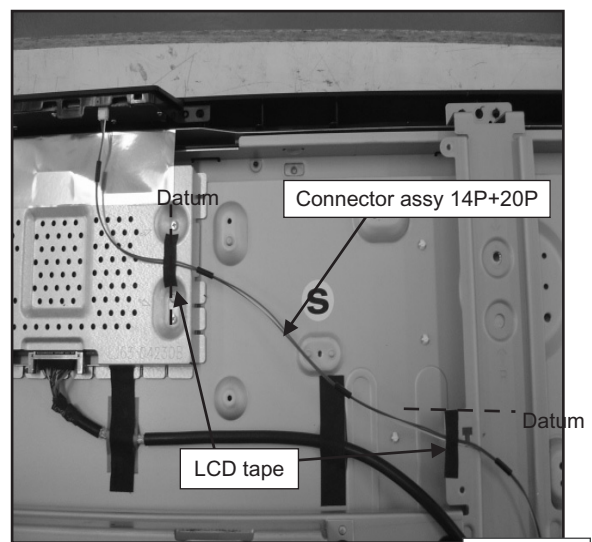
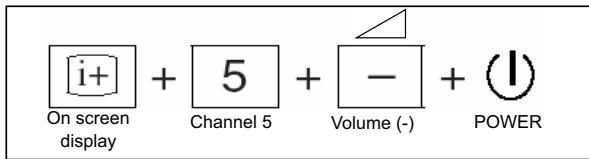

Figure Q

SECTION 5 SERVICE ADJUSTMENTS

5-1. Accessing Diagnostic Menu

- While TV set on standby, press the following sequence on the remote commander (RM-GA011).



- The following menu will appear on the screen:

ERROR		
DC_DET	0	
DC_ALERT1	0	
DC_ALERT2	0	
DC_ALERT3	0	
BACKLIGHT	0	
INTERNAL TEMP ERROR	0	
AUDIO ERROR	0	
NVM ERROR	0	
IIC ERROR	0	
BALANCER ERROR	0	
HDMI ERROR	0	
RESET	0	

Figure 1

- To reset, select 'RESET' using remote commander and press ⊕ to execute RESET.
- To quit the diagnostic menu, turn off and on the TV set.

5-2. Aging

- While TV set on standby, press the following sequence on the remote commander (RM-GA011).

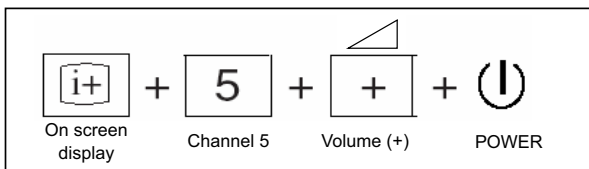

Figure 2

- The following menu will appear on the screen.

Service Menu	
Status	
W/B	
Service	

Figure 3

- Press ▲/▼ to select 'Service'.

Service Menu	
Status	
W/B	
Service	

Figure 4

- Press ◀/▶ or ⊕ to view 'Service' category items. Press ▲/▼ to select 'PATTERN'. Then press ◀/▶ then ▲/▼ to select 'WHITE PATTERN' and ⊕.

Service Menu		
Service		
TEST RESET		Cancel
PATTERN		WHITE PATTERN
PRODUCTION		11111111
APC		Normal
OVER MODULATION		Off
OPTIONS		OPT 1
AUTOSET FACTORY		DEFAULT
SERIAL NUMBER EDIT		
ET11 CLEAR		Cancel
No Signal Mute		Off

Figure 5

- The aging Condition is as the following:
 - Supply voltage : Rating
 - Time : 20 minutes or over
 - Ambient Temp : 22~28 degrees

5-3. Resetting the User Menu - Factory Reset

Note: THE TEST RESET option resets all the customer adjustable data back to factory defaults.

- While TV set on standby, press the following sequence on the remote commander (RM-GA011).

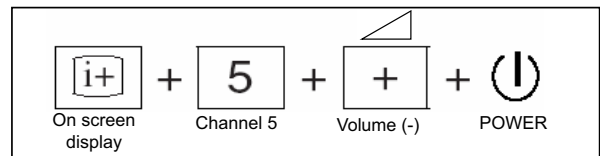

Figure 6

- The following menu will appear on the screen:

Service Menu	
Status	
W/B	
Service	

Figure 7

- Press \uparrow/\downarrow to select 'Service'.

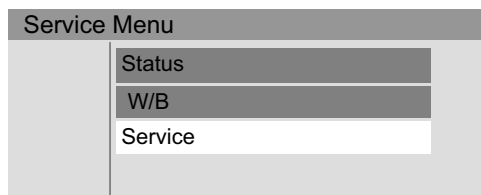

Figure 8

- Then press \leftarrow/\rightarrow or \oplus to view 'Service' category items. Next select 'TEST RESET' by pressing \uparrow/\downarrow .
- Finally press \leftarrow/\rightarrow or \oplus then \uparrow/\downarrow to select 'OK' and confirm selection by pressing \oplus .

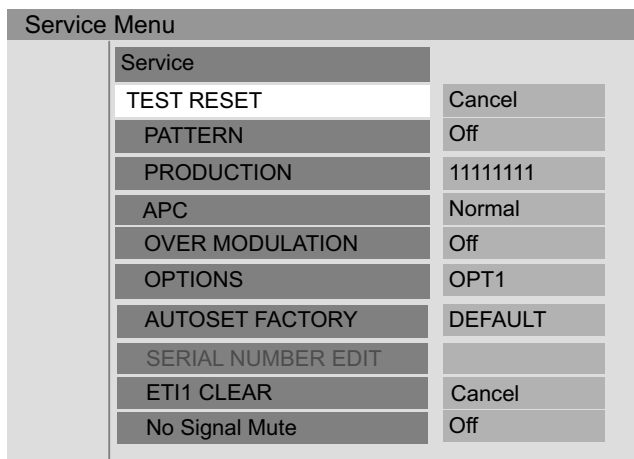

Figure 9

5-4. White Balance Adjustment

Note: The white balance need to be adjusted when BG1 board and Panel is replaced.

- While TV set on standby, press the following sequence on the remote commander (RM-GA011).

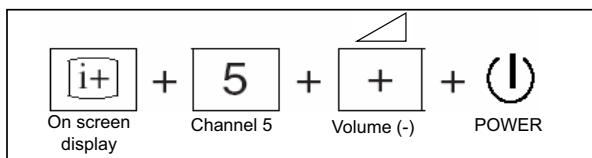

Figure 10

- The following menu will appear on the screen:

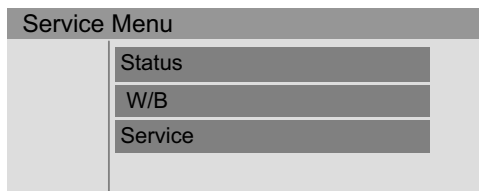

Figure 11

- Press \leftarrow/\rightarrow or \oplus to view 'W/B'.

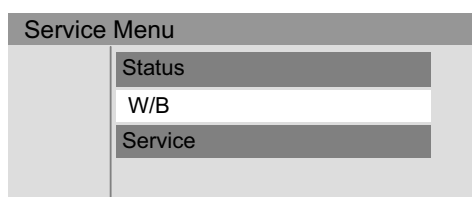

Figure 12

- Then press \leftarrow/\rightarrow or \oplus to view 'W/B' category items.

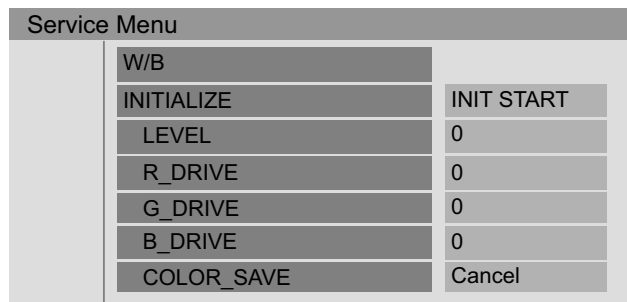

Figure 13

- Press \uparrow/\downarrow to select 'INITIALIZE'. Then press \leftarrow/\rightarrow or \oplus then \uparrow/\downarrow to select 'INIT START' and execute selection by pressing \oplus .
- W/B need to be adjusted for all LEVEL (0~4).

For Level 0

- Select 'LEVEL' using \uparrow/\downarrow and choose '0'. Then do adjustment for R_Drive, G_Drive and B_Drive. To increase/ decrease data value, press \uparrow/\downarrow .
- Once adjustment has completed for R_Drive, G_Drive and B_Drive, press \uparrow/\downarrow to select 'COLOR SAVE'. Next press \leftarrow/\rightarrow then \uparrow/\downarrow to choose 'OK' and press \oplus .
- Repeat step 7 and 8 for level 1~4.
- Once W/B adjustment has been completed for all levels (0~4), select 'INITIALIZE', choose 'INT END' and press \oplus .

5-5. Board & Panel Replacement

When replacing the BG1 board and Panel, make sure to readjust the W/B.

SECTION 6 DIAGRAMS

6-1. BLOCK DIAGRAM

Due to complexity of the board, performing component level field repairs are not recommended. Complete board replacement is required if service is necessary.

6-2. CIRCUIT BOARD LOCATION

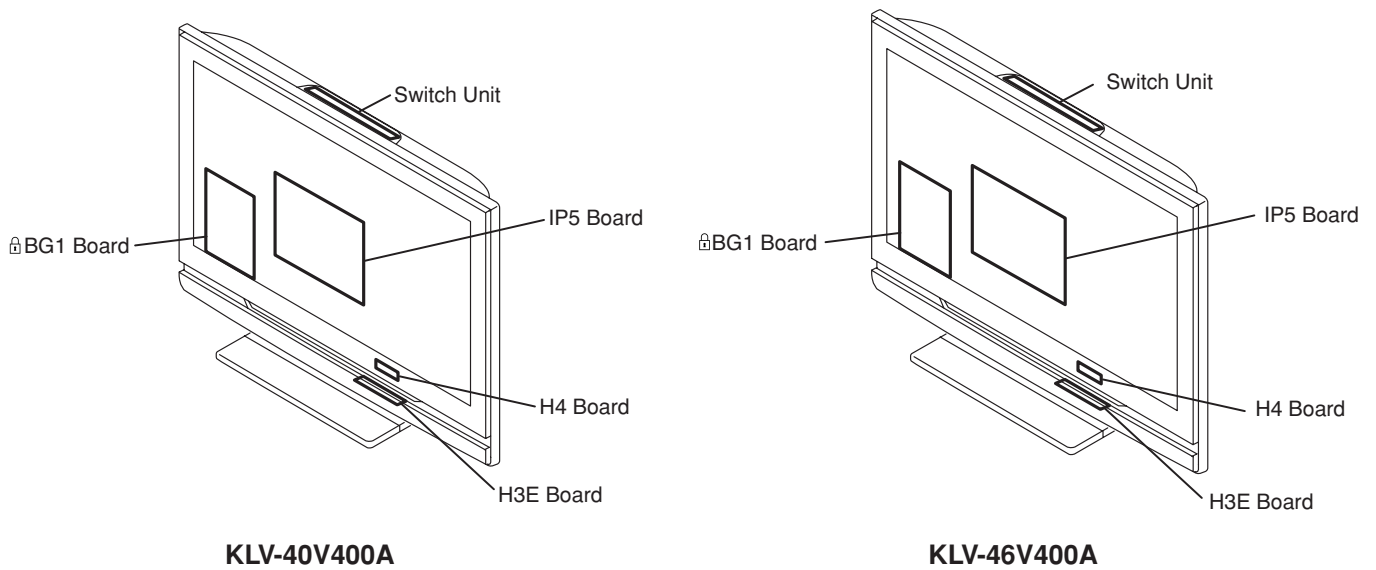

6-3. SCHEMATIC DIAGRAM

6-4. PRINTED WIRING BOARDS

Board	Function	Note
BG1	I/O/Audio/VCTP/DDR/HDMI/ DC-DC Converter/Tuner/Sub Croma/STBY Micro	Due to complexity of the board, performing component level field repairs are not recommended. Complete board replacement is required if service is necessary. Therefore schematic diagrams and printed wiring boards are not included. For part number information, refer to Exploded View or Electrical Parts List section in this manual.
IP5	Power Supply	
H3E	LED/Optical Sensor	
H4	SIRCS	

6-5. SEMICONDUCTOR

Due to complexity of the board, performing component level field repairs are not recommended. Complete board replacement is required if service is necessary.

SECTION 7 EXPLODED VIEWS

- Components not identified by a part number or description are not stocked because they are not required for routine service.
- The component parts of an assembly are indicated by the reference numbers in the far right column of the part list and within the dotted lines of the diagram.
- Item marked with an asterisk (*) are not stocked since they are seldom required for routine service. Some delay should be anticipated when ordering these components.

NOTE: The components identified by shading and \triangle mark are critical for safety. Replace only with part number specified.

Note: The components identified by mark \triangle contain confidential information. Strictly follow the instructions whenever the components are repaired and /or replaced.

a	2-580-591-01	SCREW, +PSW M3X5
b	2-580-600-01	SCREW, +PSW M4X8
c	2-580-606-01	SCREW, +PSW M5X8
d	2-580-626-01	SCREW, SP 4-40 UNC
e	2-580-629-01	SCREW, +BVST 3X8
f	2-580-640-01	SCREW, +BVTP2 4X16
g	2-580-644-01	SCREW, +KTP2 3X8
h	2-674-965-31	SCREW, +PSW 3SG
i	3-873-012-01	SCREW, +PWH M5X16
j	3-873-013-01	SCREW, +PWH M5X10
k	7-685-648-79	SCREW, +BVTP 3X12 TYPE2 IT-3
l	2-580-608-01	SCREW +PSW M5X16
m	2-596-649-01	+KTT 3X10 (5 TYPE)
n	2-580-607-01	SCREW, +PSW M5X12

7-1. (KLV-40V400A) 7-1-1. REAR CABINET AND STAND ASSY

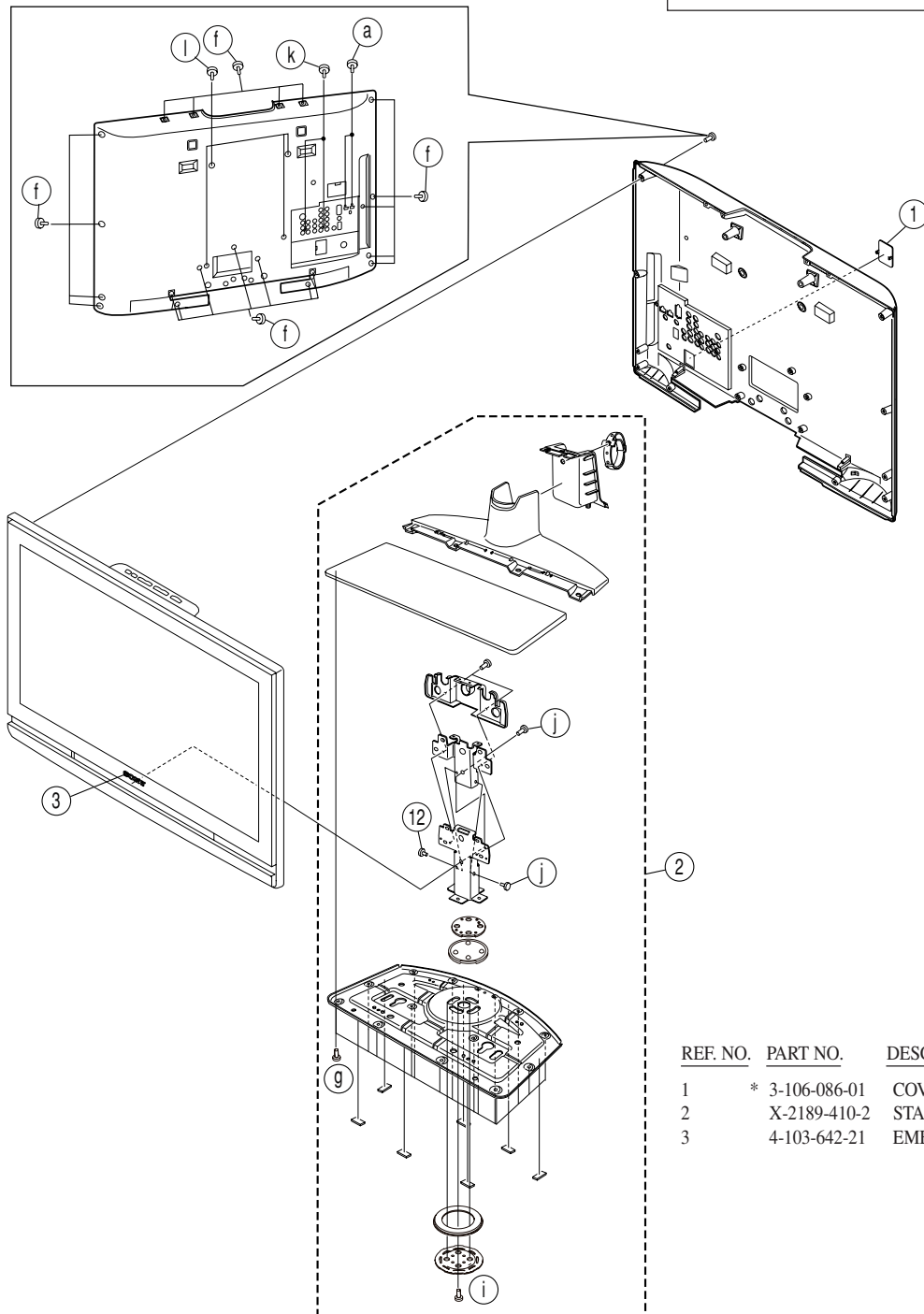

REF. NO.	PART NO.	DESCRIPTION	REMARK
1	* 3-106-086-01	COVER, ECS	
2	X-2189-410-2	STAND(ML)ASSY	
3	4-103-642-21	EMBLEM, SONY NO.8	

7-1-2. FRAME AND COVER

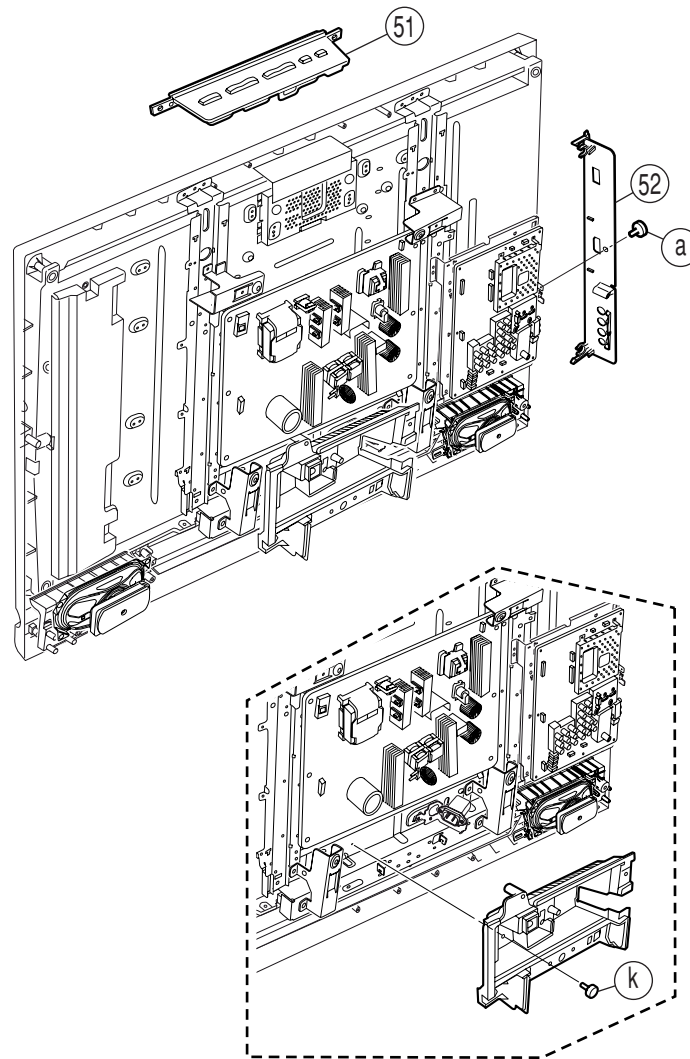

<u>REF. NO.</u>	<u>PART NO.</u>	<u>DESCRIPTION</u>	<u>REMARK</u>
51	1-480-709-11	SWITCH UNIT	
52	X-2318-678-1	BRACKET SIDE JACK ASSY (PF1)	

7-1-3. CHASSIS-1

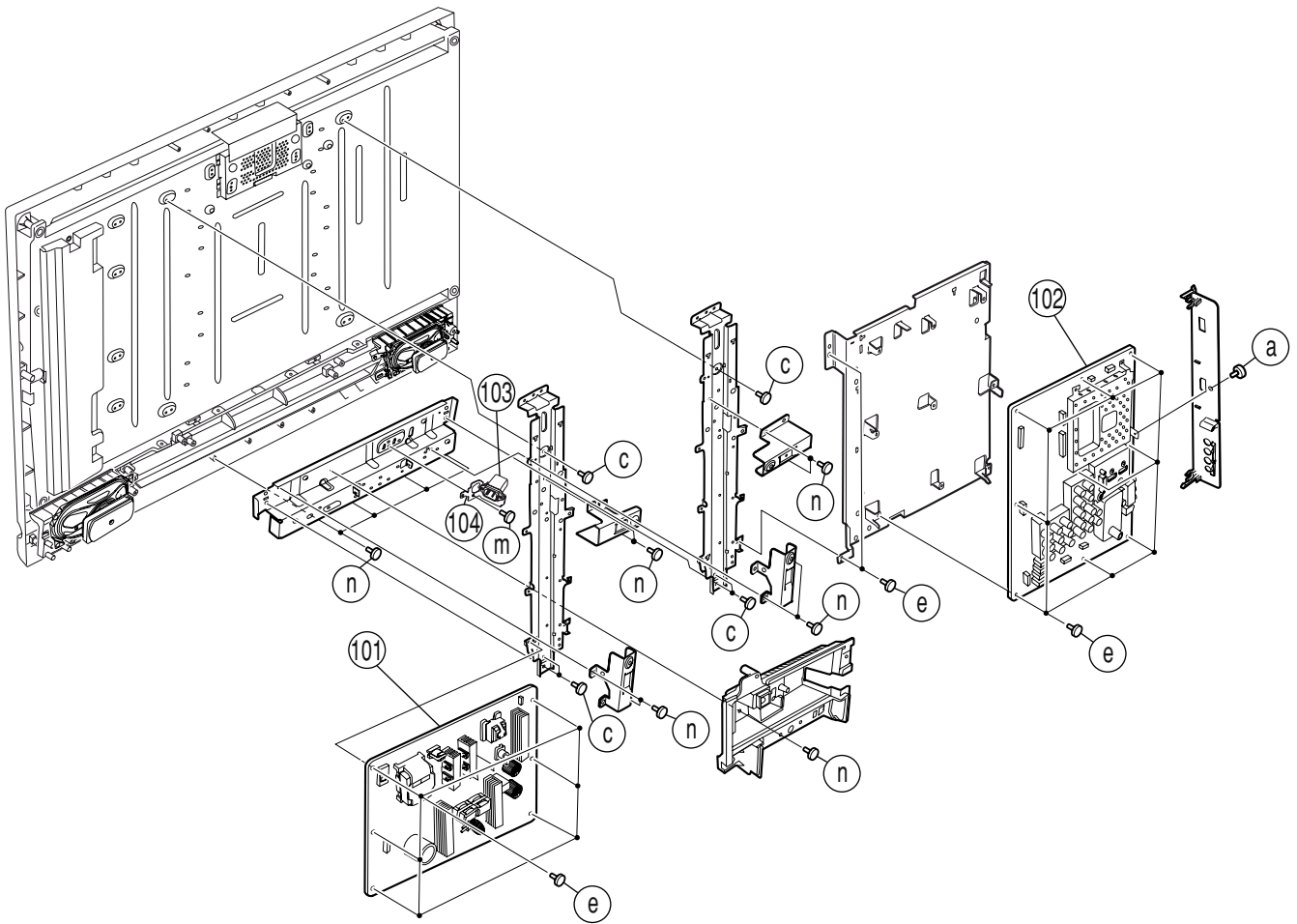

<u>REF. NO.</u>	<u>PART NO.</u>	<u>DESCRIPTION</u>	<u>REMARK</u>
101	A-1511-380-D	IP5-40S COMPL (STT) (ME, Phillipines, South Africa, Thailand)	
	A-1511-388-D	IP5-40S COMPL (SOEM) (except ME, Phillipines, South Africa, Thailand)	
102	A-1543-889-A	BG1 MOUNT (SERVICE)	
103	1-821-909-11	AC INLET	
104	3-293-964-01	BRACKET, AC INLET	

7-1-4. H3E & H4 BOARDS AND SPEAKER

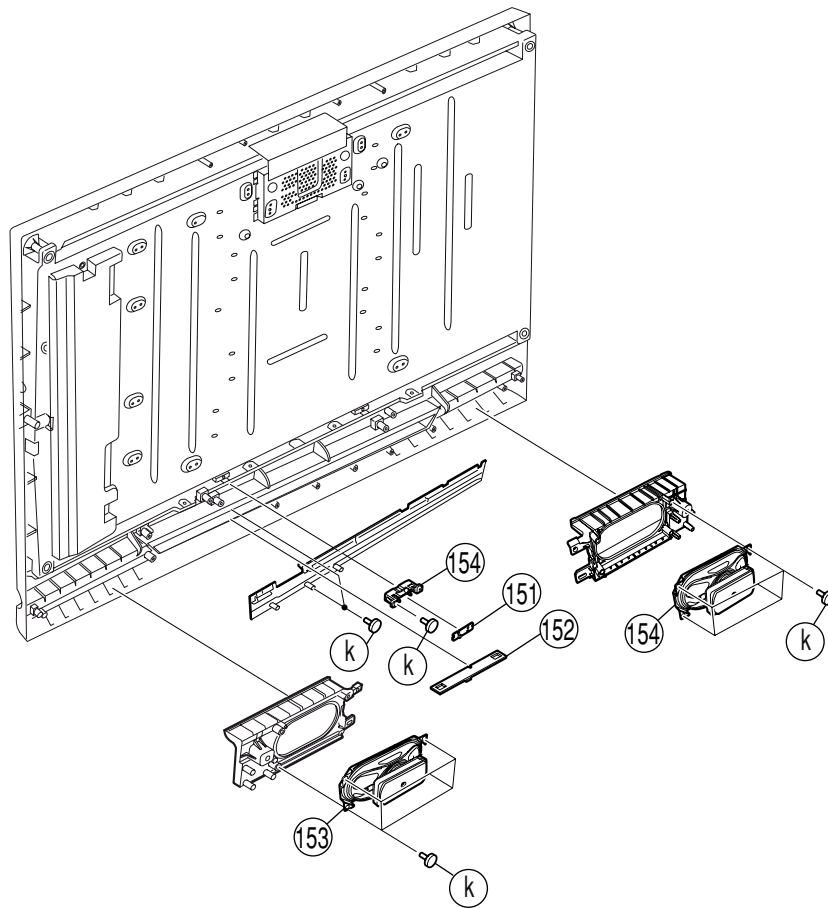

<u>REF. NO.</u>	<u>PART NO.</u>	<u>DESCRIPTION</u>	<u>REMARK</u>
151	* A-1530-492-A	H4 MOUNT	
152	* A-535-202-A	H3E MOUNT	
153	1-826-889-12	LOUDSPEAKER (5.8X12.6CM)	
154	1-826-889-22	LOUDSPEAKER (5.8X12.6CM)	
155	* 3-290-361-02	GUIDE, LIGHT	

7-1-5. BEZEL ASSY AND LCD PANEL

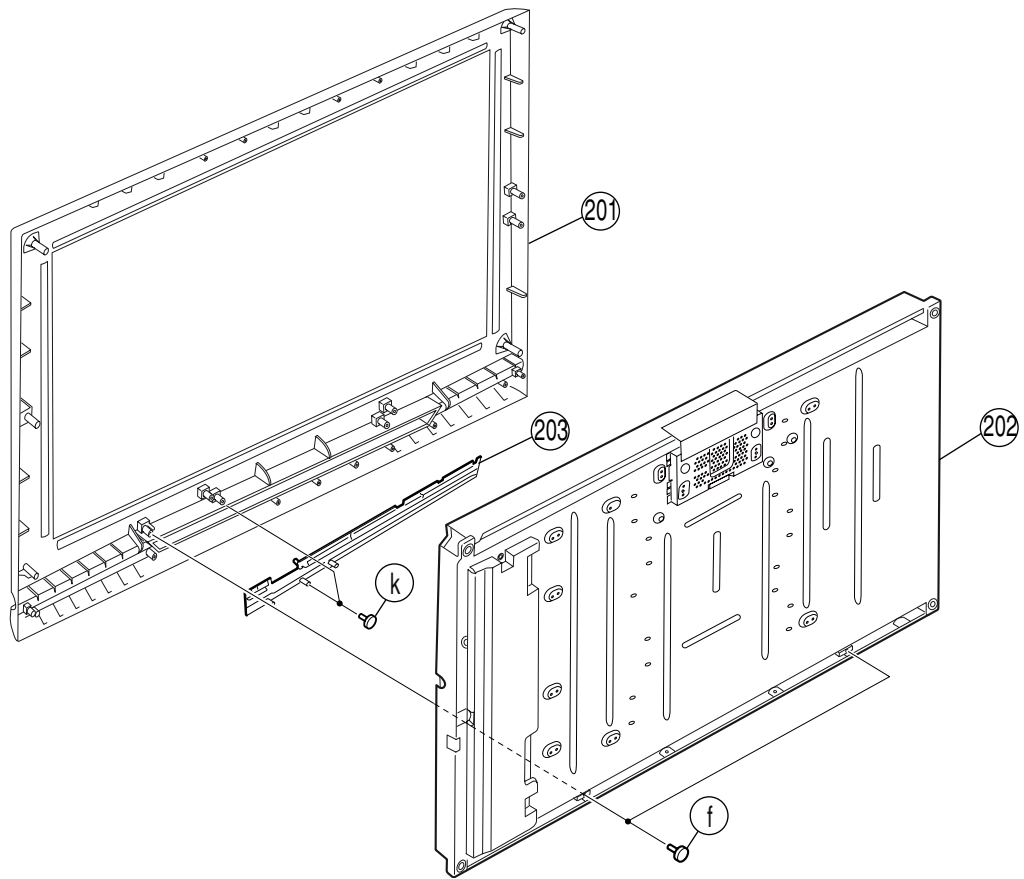

<u>REF. NO.</u>	<u>PART NO.</u>	<u>DESCRIPTION</u>	<u>REMARK</u>
201	X-2190-988-1	BEZEL ASSY (40AM)	
202	1-802-652-12	LCD PANEL (40 FHD TFT)	
203	* 3-289-965-01	PANEL, CLEAR (40)	

7-2. (KLV-46V400A)
7-2-1. REAR CABINET AND STAND ASSY

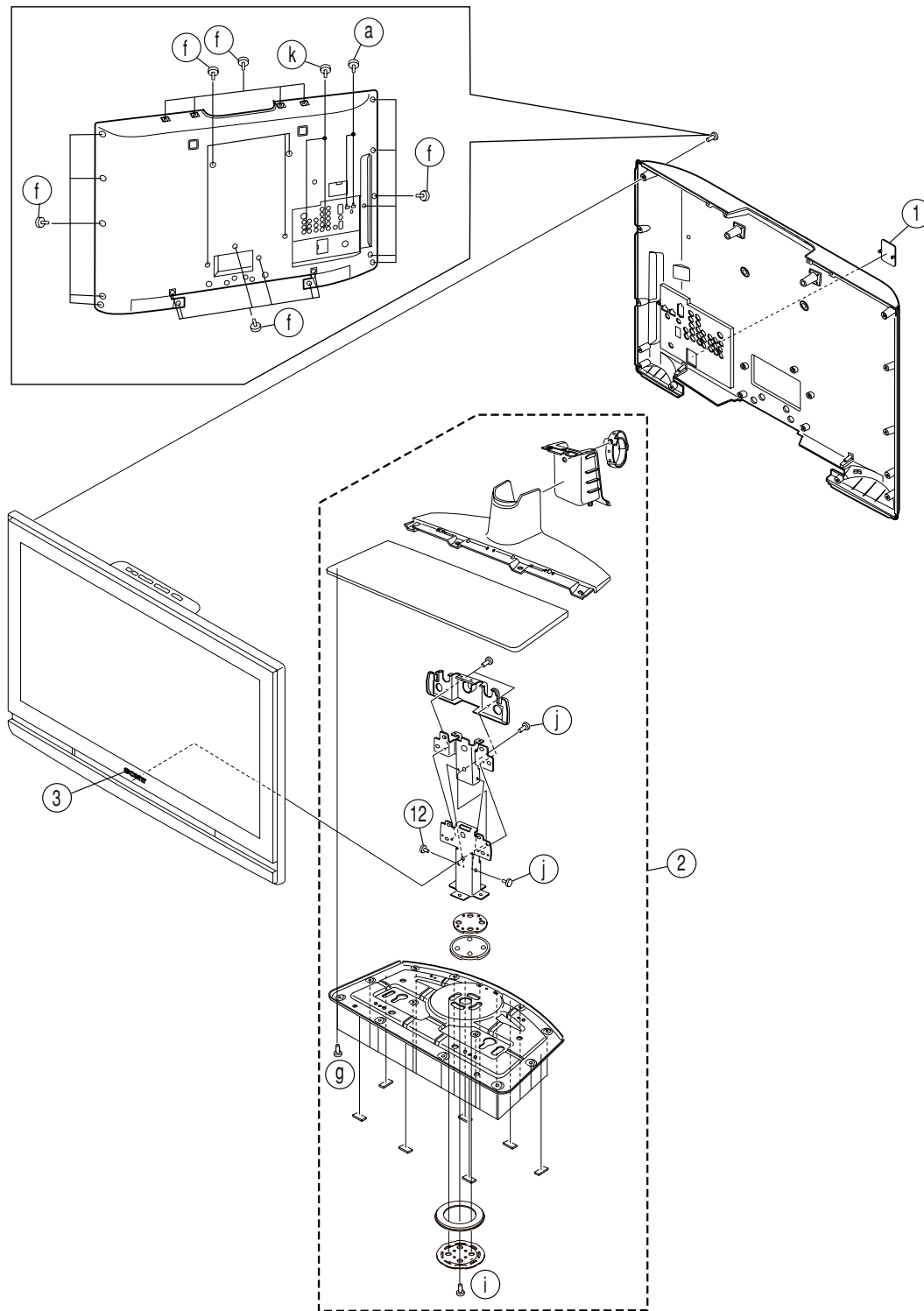

REF. NO.	PART NO.	DESCRIPTION	REMARK
1	* 3-106-086-01	COVER, ECS	
2	X-2189-411-2	STAND(L)ASSY	
3	2-635-749-11	EMBLEM, SONY NO.9	

7-2-2. FRAME AND COVER

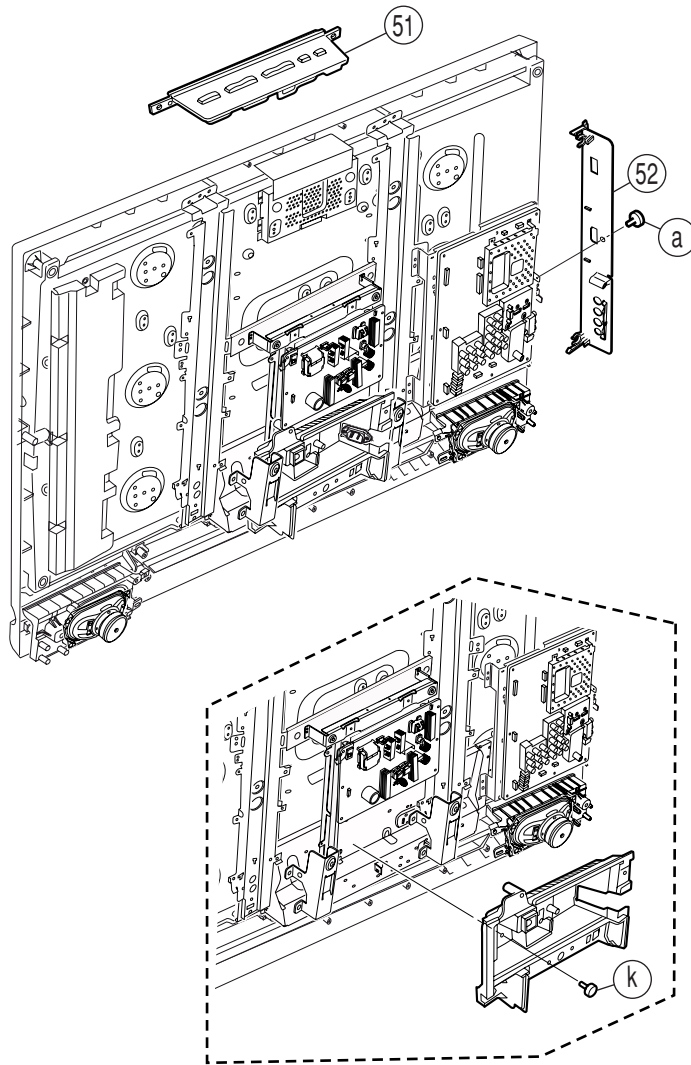

<u>REF. NO.</u>	<u>PART NO.</u>	<u>DESCRIPTION</u>	<u>REMARK</u>
51	1-480-709-11	SWITCH UNIT	
52	X-2318-678-1	BRACKET, SIDE JACK ASSY (PF1)	

7-2-3. CHASSIS-1

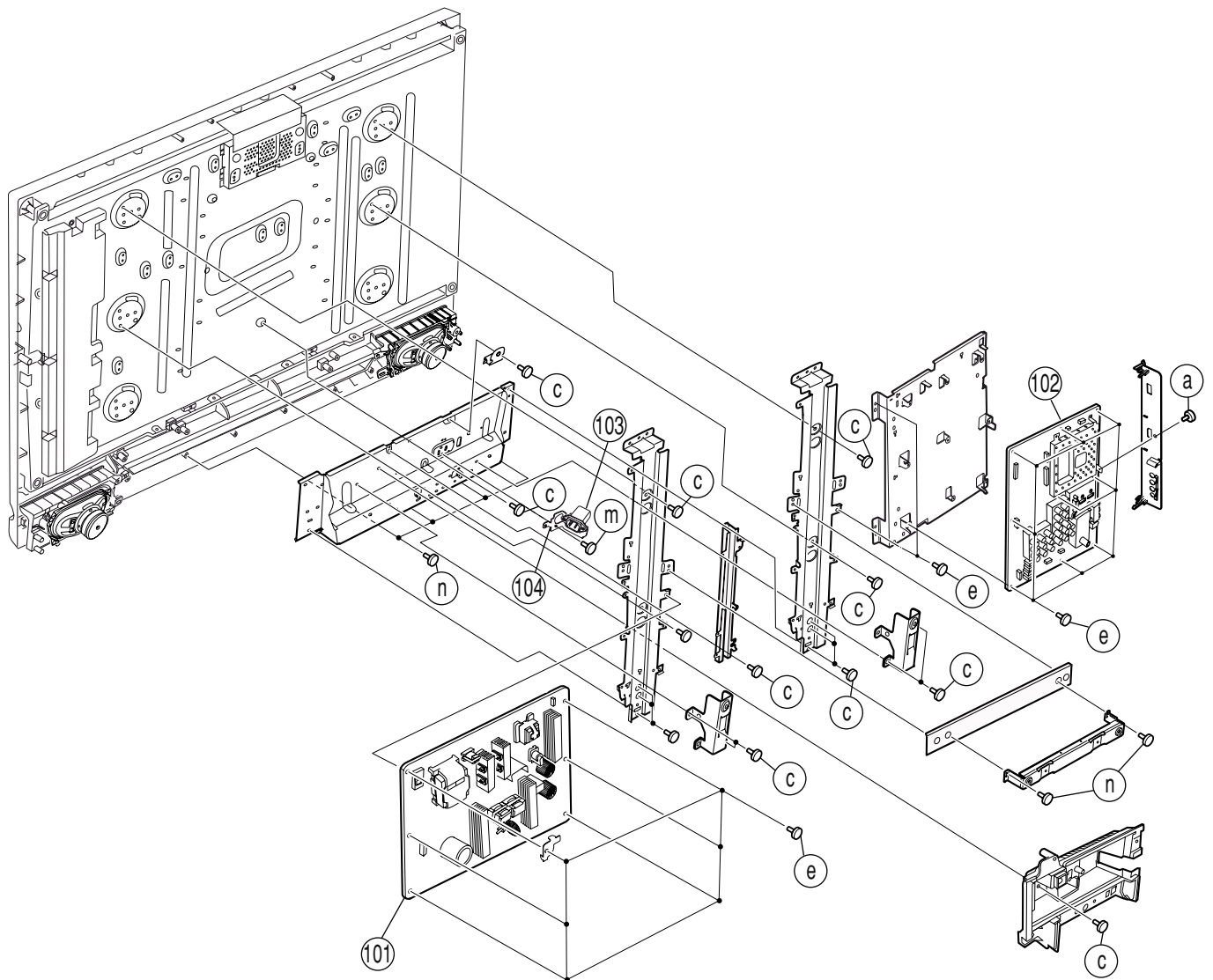

<u>REF. NO.</u>	<u>PART NO.</u>	<u>DESCRIPTION</u>	<u>REMARK</u>
101	A-1511-381-D	IP5-46 COMPL (STT) (ME, Phillipines, South Africa, Thailand)	
	A-1511-389-D	IP5-46 COMPL (SOEM) (E, EA, India, Iran, Saudi Arabia, Vietnam)	
102	🔒 A-1543-889-A	BG1 MOUNT (SERVICE)	
103	1-821-909-11	AC INLET	
104	3-293-964-01	BRACKET, AC INLET	

7-2-4. H3E & H4 BOARDS AND SPEAKER

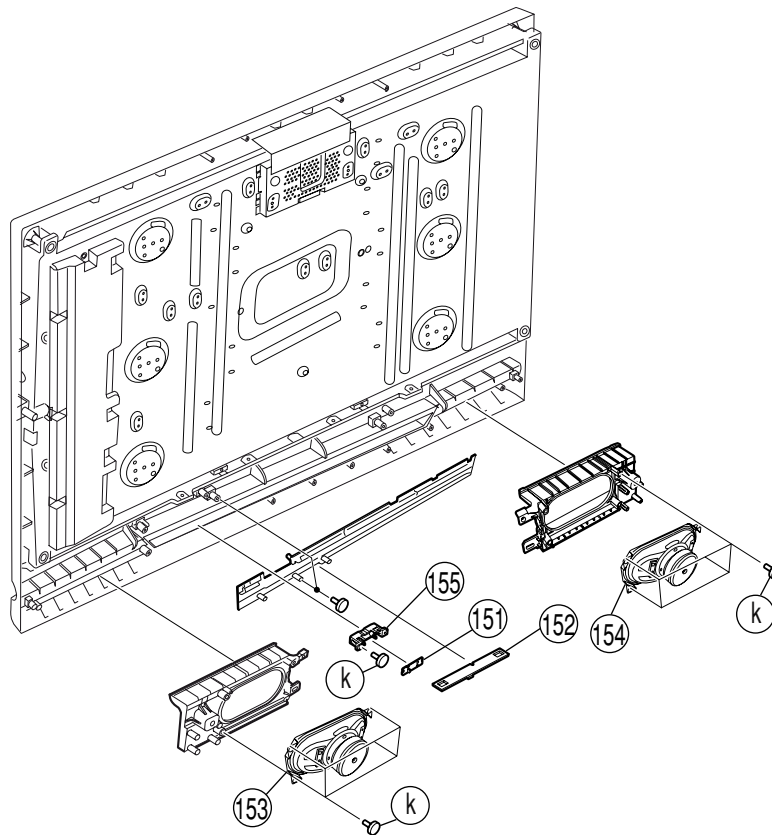

<u>REF. NO.</u>	<u>PART NO.</u>	<u>DESCRIPTION</u>	<u>REMARK</u>
151	* A-1530-492-A	H4 MOUNT	
152	* A-1535-202-A	H3E MOUNT	
153	1-826-890-12	LOUD SPEAKER (6.5X15CM)	
154	1-826-890-22	LOUD SPEAKER (6.5X15CM)	
155	* 3-290-361-02	GUIDE, LIGHT	

7-2-5. BEZEL ASSY AND LCD PANEL

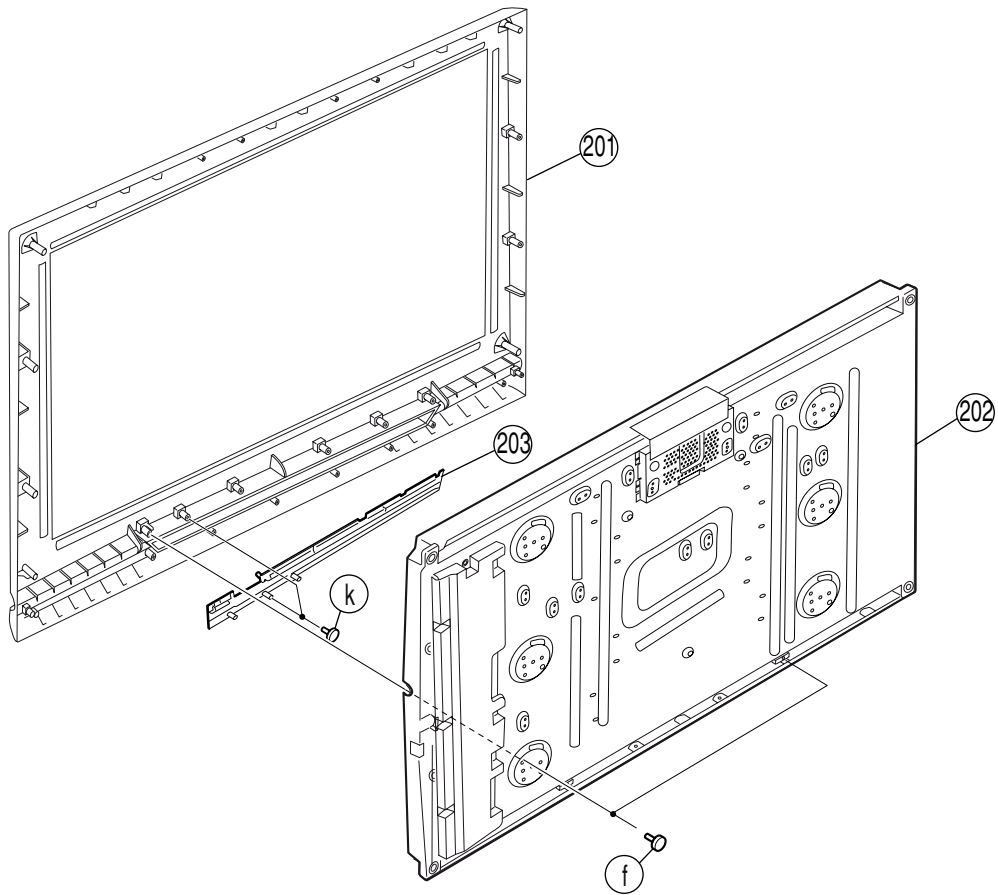

<u>REF. NO.</u>	<u>PART NO.</u>	<u>DESCRIPTION</u>	<u>REMARK</u>
201	X-2190-776-1	BEZEL ASSY (46AM)	
202	1-802-650-14	LCD PANEL (46 INCH FHD TFT)	
203	* 3-293-434-01	PANEL, CLEAR (46)	

SECTION 8 ELECTRICAL PARTS LIST

NOTE:

The components identified by shading and mark \triangle are critical for safety. Replace only with part number specified.

The components identified by mark \square contain confidential information. Strictly follow the instructions whenever the components are repaired and /or replaced.

- Items marked " * " are not stocked since they are seldom required for routine service. Some delay should be anticipated when ordering these items.

- All resistors are in ohms
- F : nonflammable

CAPACITORS

- MF : μ F, PF : μ μ F

COILS

- MMH : mH, UH : μ H

(KLV-40V400A)

<u>REF NO.</u>	<u>PART NO.</u>	<u>DESCRIPTION</u>	<u>REMARK</u>
	A-1511-380-D	IP5-40S COMPL (STT) (ME, Phillipines, South Africa, Thailand)	
	A-1511-388-D	IP5-40S COMPL(SOEM) (except ME, Phillipines, South Africa, Thailand) *****	
	\square A-1543-889-A	BG1 MOUNT(SERVICE) *****	
	* A-1535-202-A	H3E MOUNT	
	* A-1530-492-A	H4 MOUNT *****	

CONNECTORS *****			
	* 1-835-147-11	CONNECTOR ASSY, MDF61 INV-CN6700(IP5)(1)	
	1-910-043-69	CONNECTOR ASSY 20P CN9152(BG1)-CN101(H1)-CN301(H3E)-CN401(H4)- CN6154(IP5)(1)	
	1-966-106-21	HARNESS WITH CONNECTOR (LVDS) CN3002(BG1)-TCON(1)	

ACCESSORIES AND PACKING *****			
	* 3-295-295-01	CUSHION (UPPER)	
	* 3-295-296-01	CUSHION (LOWER)	
	* 3-874-545-01	INDIVIDUAL CARTON (Phillipines, E, EA, India, ME, South Africa, Saudi Arabia, Thailand)	
	4-113-863-01	INDIVIDUAL CARTON (Egypt)	
	4-106-875-01	INDIVIDUAL CARTON (Vietnam)	

Due to complexity of the board, performing component level field repairs are not recommended. Complete board replacement is required if service is necessary. For part number information refer to the Exploded View or Electrical Parts List section of this Service Manual.

<u>REF NO.</u>	<u>PART NO.</u>	<u>DESCRIPTION</u>	<u>REMARK</u>
	* 4-111-325-01	INDIVIDUAL CARTON (Iran)	
	1-835-165-11	POWER SUPPLY CORD (EA, E, Saudi Arabia, ME)	
	1-835-200-11	POWER-SUPPLY CORD (Egypt, EA, ME, Vietnam)	
	1-835-281-11	POWER-SUPPLY CORD SET (India)	
	1-835-138-11	POWER-SUPPLY CORD SET (Saudi Arabia, Phillipines)	
	1-835-166-11	POWER-SUPPLY CORD SET(South Africa)	
	1-835-126-11	POWER-SUPPLY CORD SET (Thailand)	
	3-214-128-14	SUPPLEMENT INSTRUCTION (WALL MOUNT) (E, EA, India, Saudi Arabia)	
	3-214-128-24	SUPPLEMENT INSTRUCTION (WALL MOUNT) (Phillipines, South Africa, ME, Thailand)	
	3-214-128-32	SUPPLEMENT (WALL MOUNT) (Iran)	
	3-214-128-41	SUPPLEMENT (WALL MOUNT) (Egypt)	
	3-875-982-41	LEAFLET (ATTACHING STAND) (Egypt)	
	3-219-725-13	INSTRUCTION (WALL MOUNT) (Vietnam)	
	3-300-887-12	MANUAL, INSTRUCTION (E, EA, India, Saudi Arabia)	
	3-300-887-21	MANUAL, INSTRUCTION (E) (CT Language)	
	3-300-887-31	MANUAL, INSTRUCTION (EA, Saudi Arabia) (PR LANGUAGE)	
	3-300-887-41	MANUAL, INSTRUCTION (EA) (PR Language)	
	3-874-917-11	MANUAL, INSTRUCTION (ME, Phillipines, South Africa, Thailand)	
	3-874-917-21	MANUAL, INSTRUCTION (Thailand) (Thai Language)	
	3-874-917-31	MANUAL, INSTRUCTION (ME) (CT Language)	
	3-878-303-11	MANUAL, INSTRUCTION (Vietnam) (VN Language)	
	4-108-226-51	MANUAL, INSTRUCTION (Egypt)	
	4-108-226-11	MANUAL, INSTRUCTION (WALL MOUNT) (E, EA, India, Saudi Arabia)	
	4-108-226-21	MANUAL, INSTRUCTION (WALL MOUNT) (ME, South Africa, Phillipines, Thailand)	
	4-108-226-31	MANUAL, INSTRUCTION (WALL MOUNT) (Vietnam)	
	4-108-226-41	MANUAL, INSTRUCTION (WALL MOUNT) (Iran)	
	X-2190-857-2	BAG ASSY, SCREW STAND	
	3-452-815-01	SCREW, +PSW M5X20	

		REMOTE COMMANDER *****	
	1-480-705-11	REMOTE COMMANDER (RM-GA011)	
	9-885-117-43	BATTERY COVER, REMOTE COMMANDER	

The components identified by shading and mark Δ are critical for safety. Replace only with part number specified.

The components identified by mark \square contain confidential information. Strictly follow the instructions whenever the components are repaired and /or replaced.

(KLV-46V400A)

REF NO.	PART NO.	DESCRIPTION	REMARK	REF NO.	PART NO.	DESCRIPTION	REMARK
\square A-1543-889-A	BG1 MOUNT (SERVICE) *****			X-2186-603-1	LOCK ASSY, RUDDER		
A-1535-202-A	H3E MOUNT *****			2-580-663-02	SCREW, WOOD 3.8X20		
* A-1530-492-A	H4 MOUNT *****			2-593-320-02	SCREW, CION (M6X18)		
* A-1511-381-D	IP5-46 COMPLETE (STT) (ME, Thailand, South Africa, Phillipines)			X-2190-857-2	BAG ASSY, SCREW STAND		
* A-1511-389-D	IP5-46 COMPLETE (SOEM) (E, EA, India, Iran, Saudi Arabia, Vietnam) *****			3-452-815-01	SCREW, +PSW M5X20		
				* 2-639-807-01	JOINT		
				X-2189-411-2	STAND(L)ASSY		
				3-300-887-11	MANUAL, INSTRUCTION (E, EA, India, Saudi Arabia)		
				3-330-887-22	MANUAL, INSTRUCTION (E) (CT Language)		
				3-330-887-32	MANUAL, INSTRUCTION (EA, Saudi Arabia) (AR Language)		
				3-330-887-42	MANUAL, INSTRUCTION (EA) (PR Language)		
				3-874-917-11	MANUAL, INSTRUCTION (ME, Thailand, Phillipines, South Africa)		
				3-874-917-21	MANUAL, INSTRUCTION (Thailand) (Thai Language)		
				3-874-917-31	MANUAL, INSTRUCTION (ME) (CT Language)		
				3-878-303-11	MANUAL, INSTRUCTION (Vietnam)		
				3-879-152-11	MANUAL, INSTRUCTION (Iran)		
				4-108-226-11	MANUAL, INSTRUCTION (WALL MOUNT) (E, EA, India, Saudi Arabia)		
				4-108-226-21	MANUAL, INSTRUCTION (WALL MOUNT) (ME, Thailand)		
				4-108-226-31	MANUAL, INSTRUCTION (WALL MOUNT) (Vietnam)		
				4-108-226-41	MANUAL, INSTRUCTION (WALL MOUNT) (Iran)		
				3-214-128-14	SUPPLEMENT (WALL MOUNT) (E, EA, India, Saudi Arabia)		
				3-214-128-24	SUPPLEMENT (WALL MOUNT) (ME, Thailand, South Africa, Phillipines)		
				3-214-128-32	SUPPLEMENT (WALL MOUNT) (Iran)		
*****				*****			
		CONNECTORS *****					
1-910-043-74	CONNECTOR ASSY 20P CN9152(BG1)-CN101(H1)-CN301(H3E)- CN401(H4)-CN6154(G5)(1)						
* 1-835-148-11	CONNECTOR ASSY, MDF61 INV-CN6700(IP5)(1)						
1-966-108-21	HARNESS WITH CONNECTOR (LVDS) CN3002(BG1)-TCON(1)						
*****				*****			
		ACCESSORIES AND PACKING *****				MISC *****	
* 3-295-300-02	CUSHION (LOWER)			X-2190-776-1	SPEAKER GRILLE ASSY		
* 3-295-299-02	CUSHION (UPPER)						
* 4-108-294-01	INDIVIDUAL CARTON (Iran)						
* 3-874-677-01	INDIVIDUAL CARTON (Except Iran)						
X-2190-783-1	BAG ASSY, RUDDER LOCK						
X-2186-601-2	BAG ASSY, RUDDER LOCK						
1-835-126-11	POWER SUPPLY CORD SET (Thailand)					REMOTE COMMANDER *****	
1-835-138-11	POWER SUPPLY CORD SET (Phillipines, Saudi Arabia)						
1-835-165-11	POWER SUPPLY CORD (E, EA, ME, Saudi Arabia)			1-480-705-11	REMOTE COMMANDER (RM-GA011)		
1-835-166-11	POWER SUPPLY CORD SET (South Africa)			9-885-117-43	BATTERY COVER, REMOTE COMMANDER		
1-835-200-11	POWER SUPPLY CORD (EA, Iran, ME, Vietnam)						
1-835-281-11	POWER SUPPLY CORD SET (India)						

Due to complexity of the board, performing component level field repairs is not recommended. If service is required, complete board replacement is required. Part number information refer to the Exploded View or Electrical Parts Lists section of this Service Manual.

SUPPLEMENT-1

EG1L (GA) CHASSIS

MODEL COMMANDER DEST.
KLV-40V400A/1 RM-GA001 EA

SUBJECT : New model addition KLV-40V400A/1

Note: This Supplement shows only Variant information for the new model(s).
Other information remains the same as original issue for KLV-40V400A.

SECTION 3 DISASSEMBLY

3-1. R2 board and Rear Cover Removal (refer page 8) (KLV-40V400A)

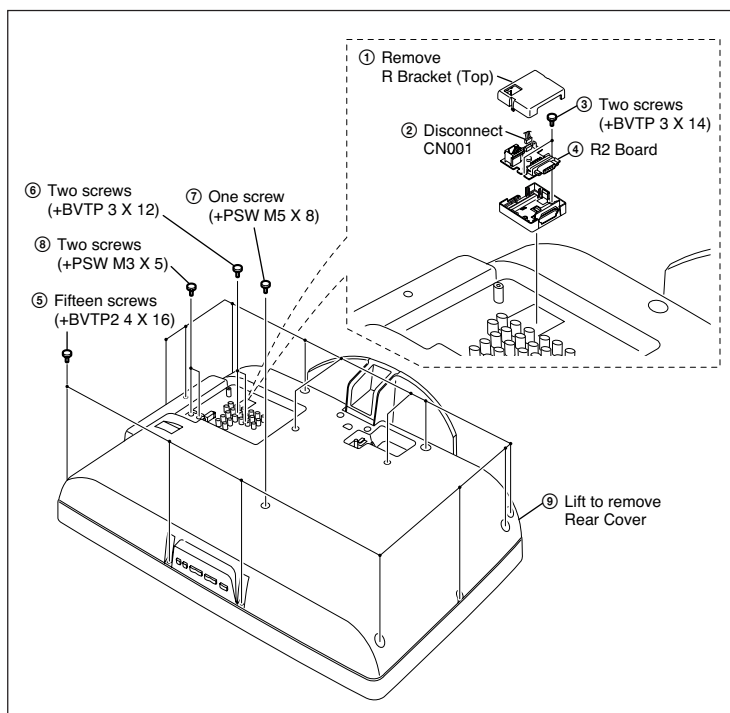

SECTION 5 SERVICE ADJUSTMENT

Preset "Test" button on remote commander

1. Press the following buttons simultaneously on the remote commander RM-GA011 for a few seconds.

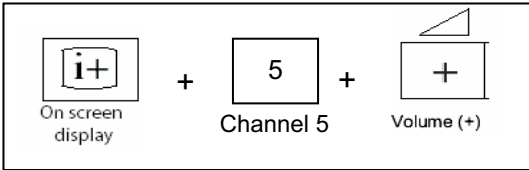

2. Once completed, the below button operates as a TEST button.

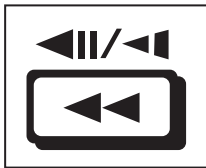

Entering Hotel Menu Mode

1. While TV set is on standby, press the following sequence on the remote commander(RM-GA011).

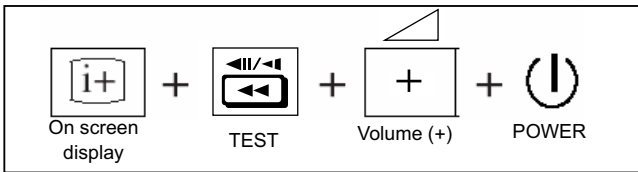

2. When the TV turns on, the indication "Hotel Mode Settings in Progress" appears on the bottom center of the screen.

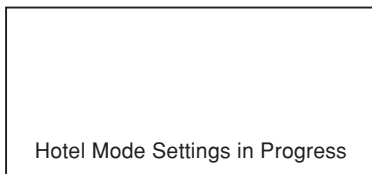

3. Press 'Menu' on the remote commander.
4. The following menu appears on the screen:

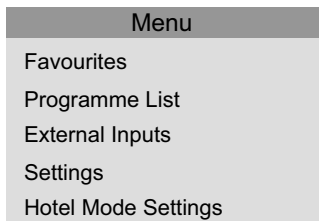

5. Press \uparrow/\downarrow to select 'Hotel Mode Settings' and press \oplus .

6. The following menu appears on the screen.

Function Settings	
Hotel Mode	Off
TV / Remote Controls	Both Controls
Freeze	Use
Display Key	Use
AC Power On Setting	Unspecify
Wide Mode Key	Use
Initialize Hotel Settings	

7. Press \leftarrow/\rightarrow to select 'Hotel Mode'.
8. Now press \leftarrow/\rightarrow then \uparrow/\downarrow to select 'ON' and press \oplus .

Function settings	
Hotel Mode	On
	Off

9. The TV set resets and restarts.
10. Now press 'Menu' on the remote commander.
11. The following menu confirms the hotel mode is ON.

Language
Sleep Timer

Exiting Hotel Menu Mode

1. While TV set is ON, press the following sequence on the remote commander(RM-GA011).

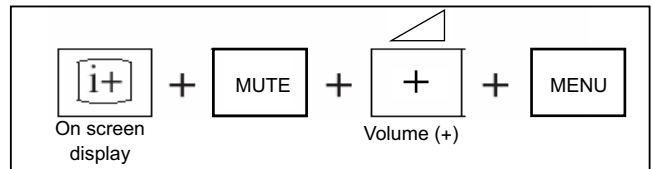

2. The TV set restarts and show "Hotel Mode Settings in Progress" on the bottom center of the screen.

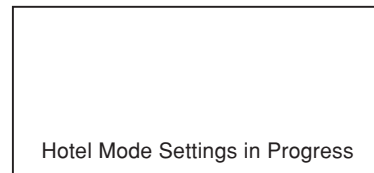

3. Now press 'Menu' on the remote commander.
4. The following menu confirms the hotel mode is OFF.

Menu
Favourites
Programme List
External Inputs
Settings
Hotel Mode Settings

Disable Hotel Menu Mode

1. While TV set is on standby, press the following sequence on the remote commander(RM-GA011).

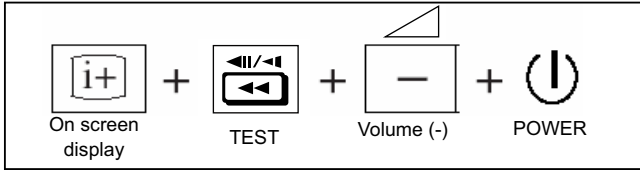

2. Press 'Menu' on the remote commander.
3. The below menu appears on the screen.



4. This menu confirms the hotel menu mode is disabled.

**SECTION 6
DIAGRAMS**

6-2. Circuit Board Location (refer page 20)

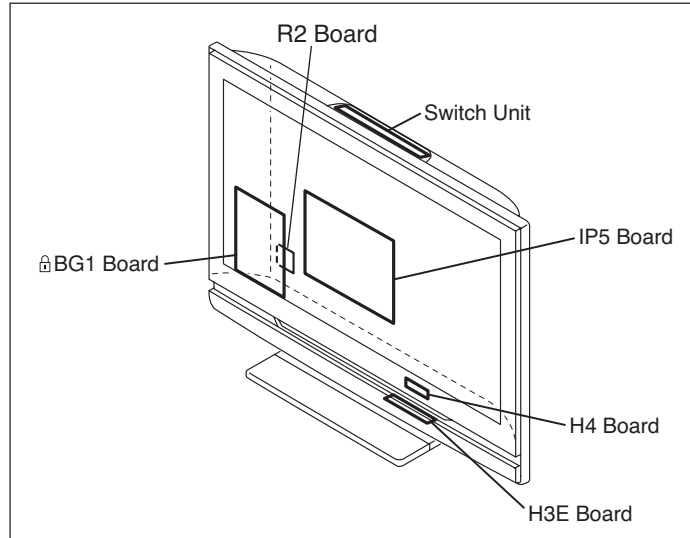

(KLV-40V400A/1)

**6-3. SCHEMATIC DIAGRAM & PRINTED WIRING BOARDS
R2 Board (refer page 21)**

Board	Function	Note
R2	Hotel Mode	Due to complexity of the board, performing component level field repairs are not recommended. Complete board replacement is required if service is necessary. Therefore schematic diagrams and printed wiring boards are not included. For part number information, refer to Exploded View or Electrical Parts List section in this manual.

SECTION 7 EXPLODED VIEW

7-1. (KLV-40V400A)

7-1-1. Rear Cabinet and Stand Assy (refer page 22)

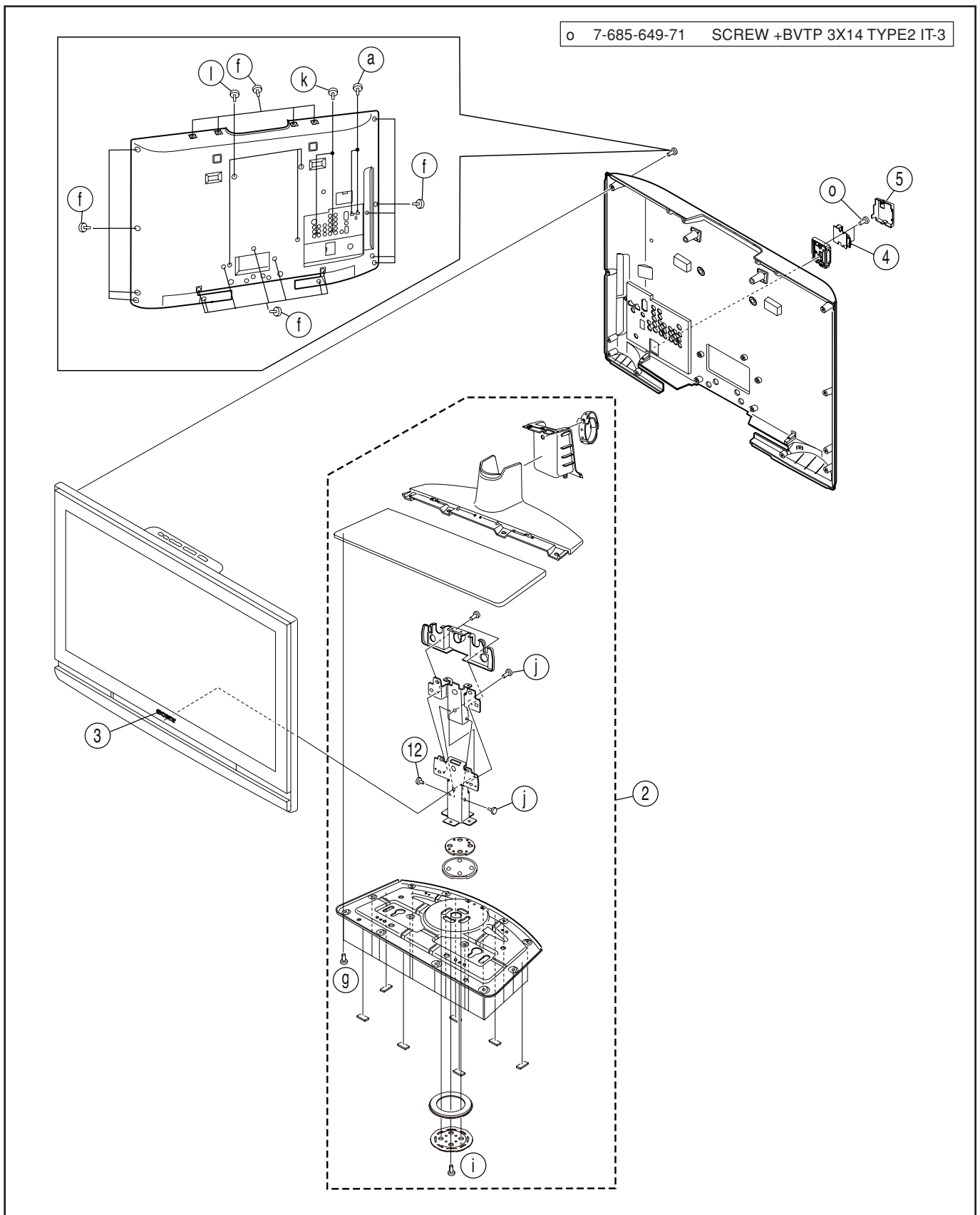

o 7-685-649-71 SCREW +BVTP 3X14 TYPE2 IT-3

REF. NO.	PART NO.	DESCRIPTION	REMARK
4	* A-1565-554-A	R2, MOUNT	
5	* 4-111-643-01	R BRACKET (TOP)	

7-1-3. CHASSIS-1

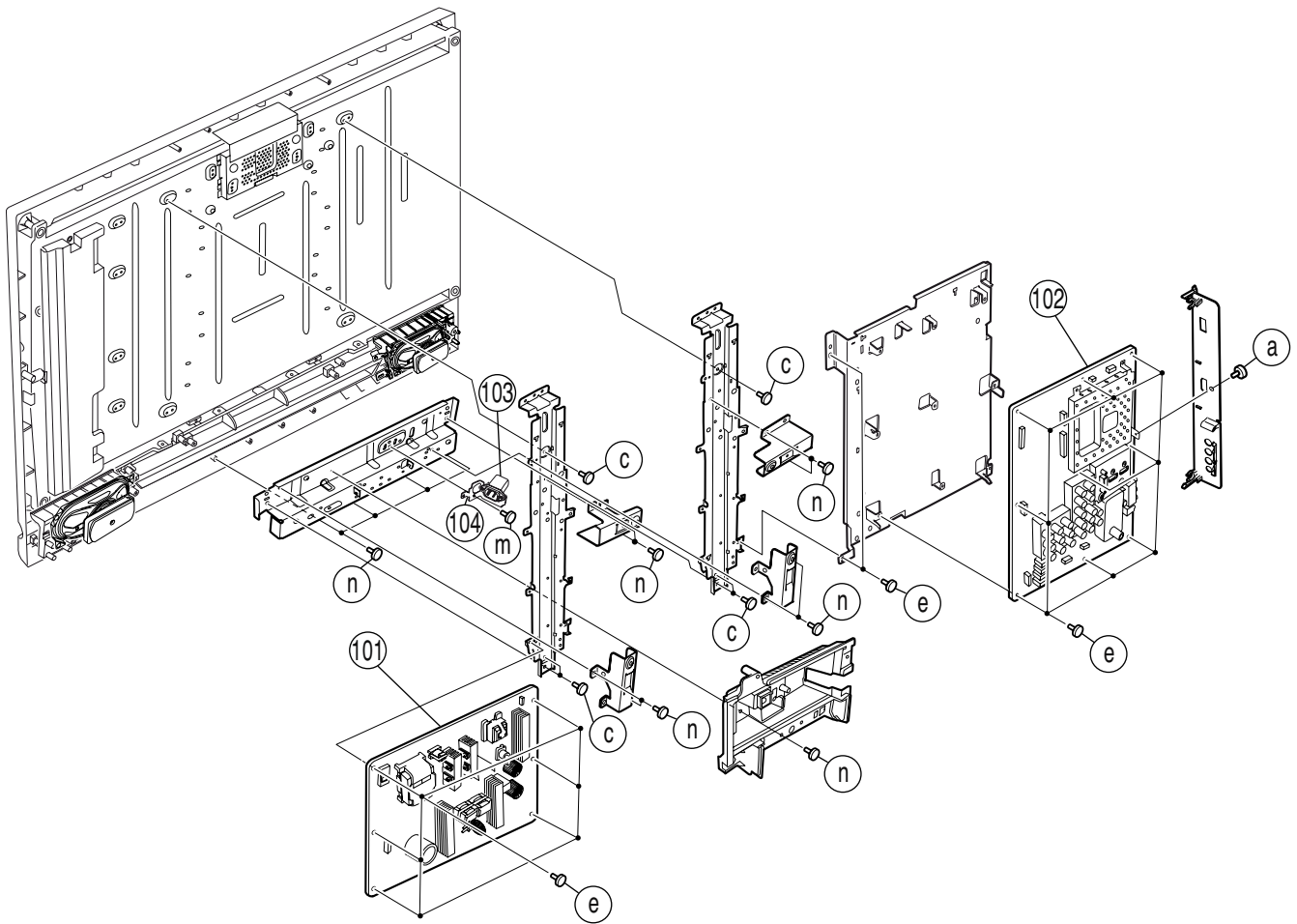

<u>REF. NO.</u>	<u>PART NO.</u>	<u>DESCRIPTION</u>	<u>REMARK</u>
102	A-1565-610-A	BG1 MOUNT (SERVICE)	

SECTION 8 ELECTRICAL PARTS LIST

(KLV-40V400A)

<u>REF NO.</u>	<u>PART NO.</u>	<u>DESCRIPTION</u>	<u>REMARK</u>
	* A-1565-610-A	BG1 MOUNT (SERVICE)	
	* A-1565-554-A	R2 MOUNT	

Due to complexity of the board, performing component level field repairs are not recommended.
Complete board replacement is required if service is necessary.
For part number information refer to the Exploded View or Electrical Parts List section of this Service Manual.

CONNECTORS *****

* 1-910-049-38	CONNECTOR ASSY, 6P (CN001(R2)-CN9003(BG1) (1)
----------------	--

SONY®

LCD Colour TV

Operating Instructions

KLV-46V400A

KLV-40V400A

KLV-32V400A

BRAVIA

Introduction

Thank you for choosing this Sony product.
Before operating the TV, please read this manual thoroughly and retain it for future reference.

The illustrations used in this manual are of the KLV-32V400A unless otherwise stated.

Trademark information

- HDMI, the HDMI logo and High-Definition Multimedia Interface are trademarks or registered trademarks of HDMI Licensing LLC.
- “BRAVIA” and BRAVIA are trademarks of Sony Corporation.



Table of Contents

Start-up Guide 4

Checking the accessories	4
Inserting batteries into the remote.....	4
1: Attaching the stand	4
2: Connecting an antenna/cable/VCR.....	5
3: Preventing the TV from toppling over.....	6
4: Bundling the cables	6
5: Connecting the AC power cord	6
6: Performing the initial set-up	7
Selecting the language.....	7
Auto-tuning the TV	7
Watching TV	8
Adjusting the viewing angle of the TV	8
Adjust the angle left and right (swivel)	8
Detaching the Table-Top Stand from the TV.....	9
Safety information	10
Precautions	11
Overview of the remote	12
Using the Tools menu	15
Overview of the TV buttons and indicators	16

Using Optional Equipment

Connecting optional equipment.....	17
Viewing pictures from the connected equipment	18
Viewing Twin Picture	20
Viewing PIP (Picture in Picture)	20
Using BRAVIA Sync (Control for HDMI) ...	21
To connect the equipment that is compatible with control for HDMI	21
To make the control for HDMI settings ...	21
Control for HDMI	21

Using MENU Functions

Navigating through menus.....	22
Using the Favourite List.....	23
Settings adjustment	24
Picture menu	26
Sound menu	27
Screen menu	28
Set-up menu.....	29
PC Settings menu.....	32
Channel Set-up menu	33

Additional Information

Specifications	35
Troubleshooting.....	36

Start-up Guide

Checking the accessories

AC power cord* (KLV-46/40V400A only)

Stand (1) and screws (3) (KLV-32V400A)

Stand (1) and screws (4) (KLV-46/40V400A)

Remote RM-GA011 (1)

Size AA batteries (R6 type) (2)

* For models with ferrite cores, do not remove these cores.

Inserting batteries into the remote

Push and lift the cover to open.

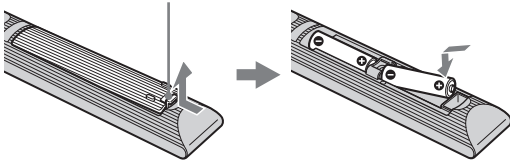

- Observe the correct polarity when inserting batteries.
- Do not use different types of batteries together or mix old and new batteries.
- Dispose of batteries in an environmentally friendly way. Certain regions may regulate the disposal of batteries. Please consult your local authority.
- Handle the remote with care. Do not drop or step on it, or spill liquid of any kind onto it.
- Do not place the remote in a location near a heat source, a place subject to direct sunlight, or a damp room.

1: Attaching the stand

► For KLV-46V400A/KLV-40V400A

1

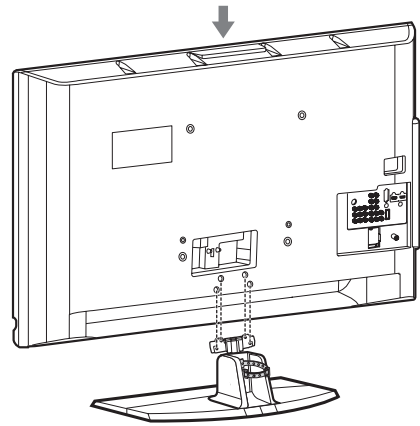

2

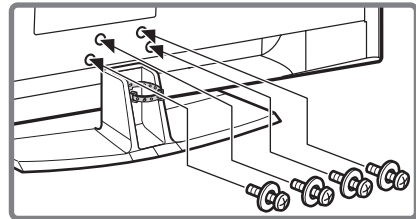

1

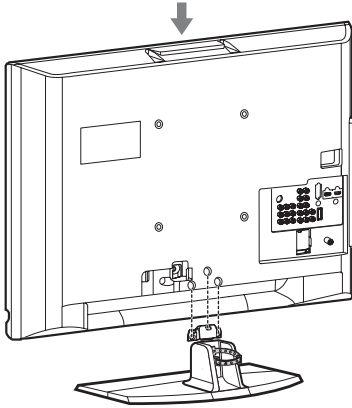

2

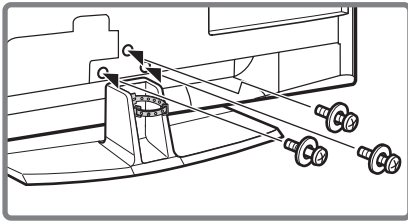

1 Place the TV onto the stand by aligning the screw hole alignment lines over the stand as shown.

2 Fix the TV to the stand according to the arrow marks that guide the screw holes using the supplied screws.

- This TV is very heavy, so two or more people should place the TV on the stand.
- If using an electric screwdriver, set the tightening torque at approximately 1.5N·m (15kgf·cm).
- When installing the TV onto the wall, follow step 1 to prevent the TV panel from falling over.
- Ensure the AC power cord is away from screw holes during stand installation to avoid damage to the AC power cord (KLV-32V400A only).

2: Connecting an antenna/cable/VCR

Connecting an antenna/cable

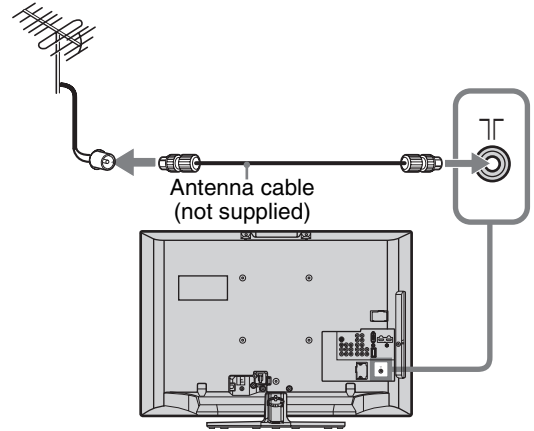

Connecting an antenna/cable and VCR

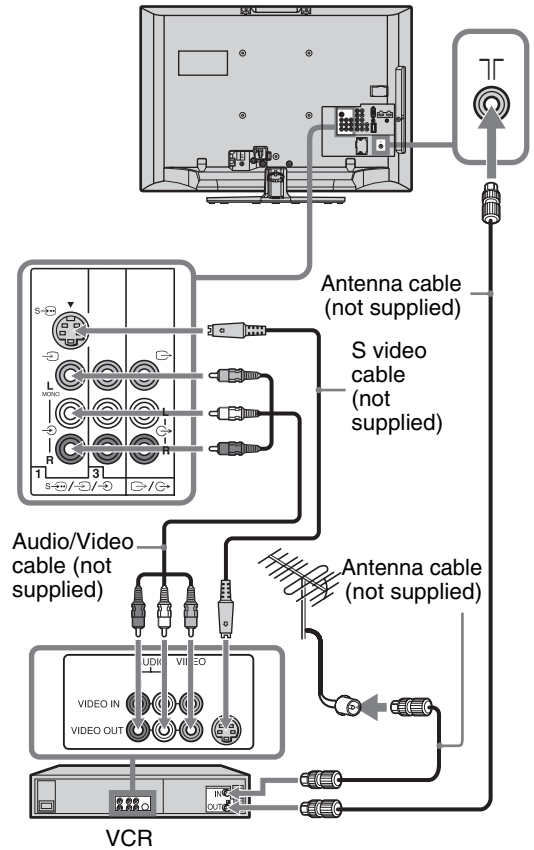

3: Preventing the TV from toppling over

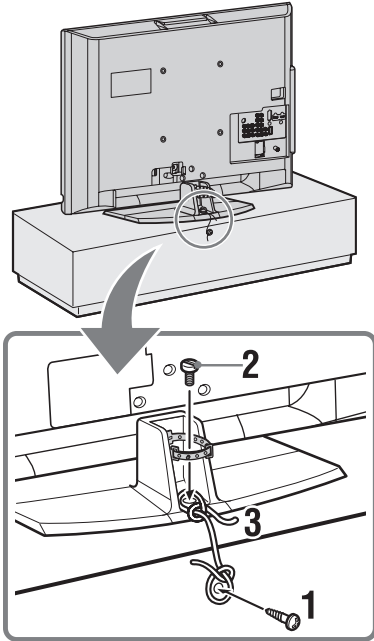

- 1 Install a wood screw (4 mm in diameter, not supplied) in the TV stand.
- 2 Install a machine screw (M5 x 12, not supplied) into the screw hole of the TV.
- 3 Tie the wood screw and the machine screw with a strong cord.

4: Bundling the cables

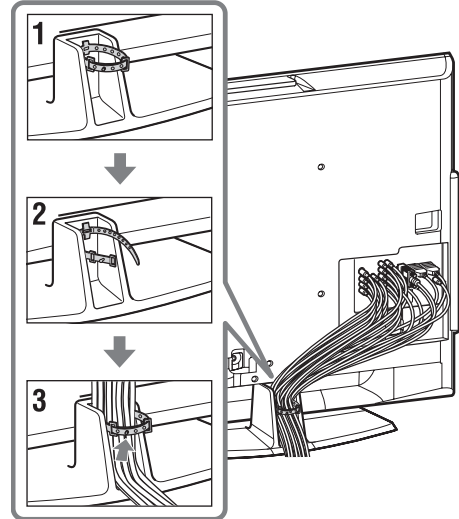

5: Connecting the AC power cord

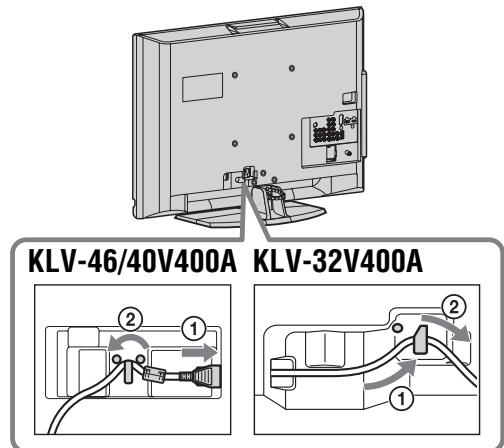

* Type of AC power cord supplied (with or without ferrite core) varies depending on the countries.

6: Performing the initial set-up

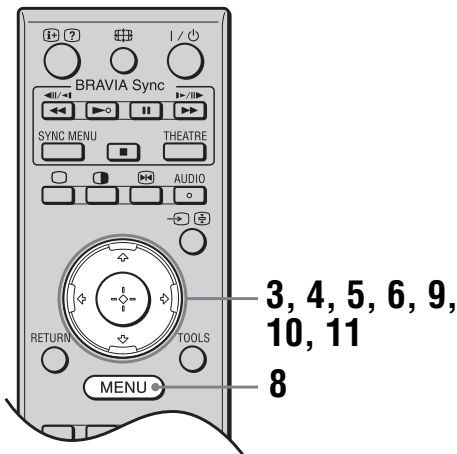
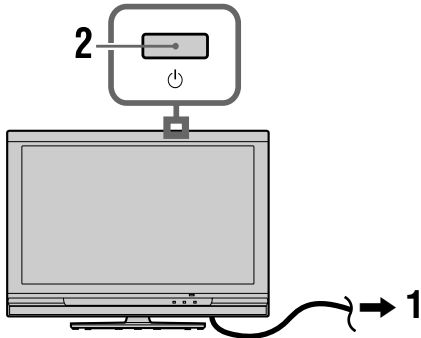

3 Press \uparrow/\downarrow to select the language displayed on the menu screens, then press \oplus .

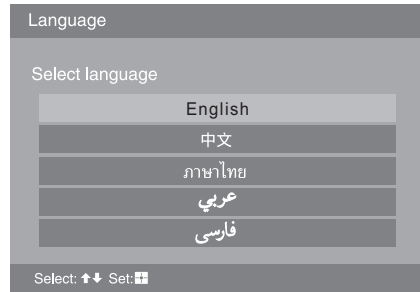

4 Press \uparrow/\downarrow to select the country/region, then press \oplus .



• Area 1: Asia (except Philippines), Middle East, Africa and Oceania.
Area 2: Philippines.

5 Press \uparrow/\downarrow to select "Home", then press \oplus .



Selecting the language

- 1 Connect the TV to your AC power outlet (110-240 V AC, 50/60 Hz).
- 2 Press ⏏ on the top edge of the TV.
When the TV is in standby mode (the ⏏ (standby) indicator on the TV front panel is red), press I/⏏ on the remote to turn on the TV.
When you turn on the TV for the first time, the "Language" menu appears on the screen.

Auto-tuning the TV

6 Press \leftarrow/\rightarrow to select "OK", then press \oplus .

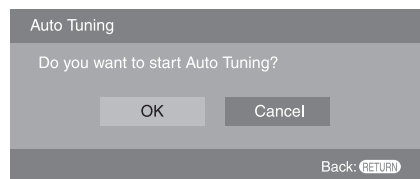

The TV starts searching for all available channels. This may take some time, please be patient and do not press any buttons on the TV or remote.

If a message appears for you to confirm the antenna connection

No programmes found. Please connect antenna (aerial) and select "Confirm" to start auto-tuning again. If 100 channels are found, auto-tuning is stopped.

- 7** When the “Programme Sorting” menu appears on the screen, follow the steps of “Programme Sorting” (page 33).

If you do not change the order in which the channels are stored on the TV, go to step 8.

- 8** Press MENU to exit.

The TV has now tuned in all the available channels.

- 9** Select day and time.

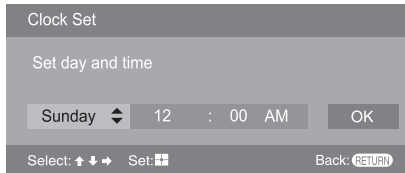

- 10** Select “Yes” to link the operations of the TV and the connected equipment that is compatible with control for HDMI automatically.



- 11** Press \leftarrow/\rightarrow to select the desired setting in “Display this menu next time?” dialogue, then press \oplus to exit.

- If “Yes” is selected and the TV is turned off by pressing \odot on the TV, or is disconnected from the AC power outlet, the initial set-up procedure restarts the next time the TV is turned on.

Watching TV

- 1** Press \odot on the top edge of the TV to turn on the TV.
- 2** Press the number buttons or PROG +/- to select a TV channel.
- 3** Press \triangleleft +/- to adjust the volume.

Adjusting the viewing angle of the TV

This TV can be adjusted within the angles shown below.

Adjust the angle left and right (swivel)

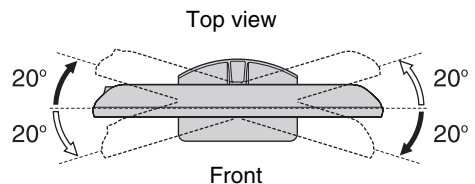

Detaching the Table-Top Stand from the TV

Remove the screws guided by the arrow marks  of the TV.

Do not remove the Table-Top Stand for any reason other than to wall-mount the TV.

► For KLV-46V400A/KLV-40V400A

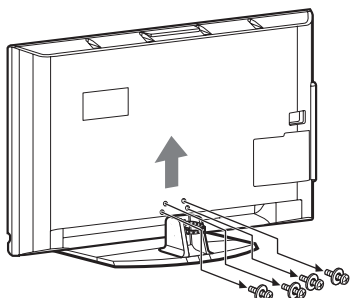

► For KLV-32V400A

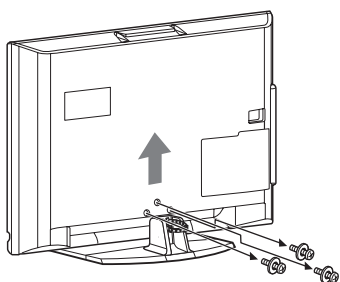

-  • For bracket installation, refer to the instruction guide provided by the Wall-Mount Bracket model for your TV. Sufficient expertise is required in installing this TV, especially to determine the strength of the wall for withstanding the TV's weight. **For product protection and safety reasons, Sony strongly recommends that you use the Wall-Mount Bracket model designed for your TV and the wall-mounting of your TV should be performed by Sony dealers or licensed contractors.**

Safety information

Installation/Set-up

Install and use the TV set in accordance with the instructions below in order to avoid any risk of fire, electrical shock or damage and/or injuries.

Installation

- The TV set should be installed near an easily accessible AC power outlet.
- Place the TV set on a stable, level surface to avoid it from falling down and cause personal injury or damage to the TV.
- Only qualified service personnel should carry out wall installations.
- For safety reasons, it is strongly recommended that you use Sony accessories, including:
Wall-mount bracket SU-WL500 and SU-WL50B
TV stand SU-FL300M
- Be sure to use the screws supplied with the Wall-mount bracket when attaching the mounting hooks to the TV set. The supplied screws are designed so that they are 8 mm to 12 mm in length when measured from the attaching surface of the mounting hook. The diameter and length of the screws differ depending on the Wall-mount bracket model. Use of screws other than those supplied may result in internal damage to the TV set or cause it to fall, etc.

8mm - 12mm

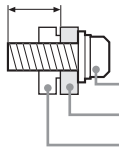

Screw (supplied with the Wall-mount bracket)
Mounting Hook
Hook attachment on rear of TV set

Transporting

- Before transporting the TV set, disconnect all cables.
- Two or more people are needed to transport a large TV set.
- When transporting the TV set by hand, hold it as shown on the right. Do not put stress on the LCD panel.
- When lifting or moving the TV set, hold it firmly from the bottom.
- When transporting the TV set, do not subject it to jolts or excessive vibration.
- When transporting the TV set for repairs or when moving, pack it using the original carton and packing material.

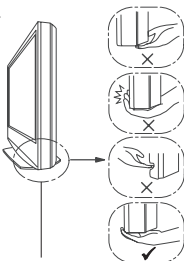
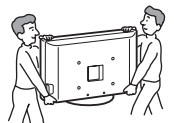

Be sure to hold the bottom of the panel, not the front part. Do not handle with dent area. Do not handle with the transparent bottom part.

Ventilation

- Never cover the ventilation holes or insert anything in the cabinet.
- Leave space around the TV set as shown below.
- It is strongly recommended that you use a Sony wall-mount bracket in order to provide adequate air-circulation.

Installed on the wall

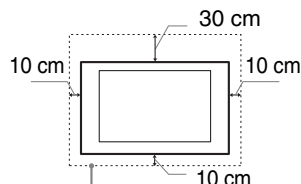

Leave at least this space around the set.

Installed with stand

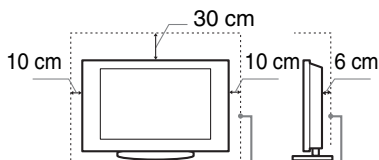

Leave at least this space around the set.

- To ensure proper ventilation and prevent the collection of dirt or dust:
 - Do not lay the TV set flat, install upside down, backwards, or sideways.
 - Do not place the TV set on a shelf, rug, bed or in a closet.
 - Do not cover the TV set with a cloth, such as curtains, or items such as newspapers, etc.
 - Do not install the TV set as shown below.

Air circulation is blocked.

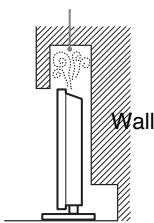

Air circulation is blocked.

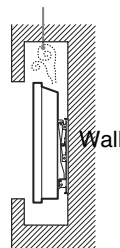

AC power cord

Handle the AC power cord and outlet as follows in order to avoid any risk of fire, electrical shock or damage and/or injuries:

- Use only Sony supplied AC power cords, not those of other brands.
- Insert the plug fully into the AC power outlet.
- Operate the TV set on a 110-240 V AC supply only.
- When wiring cables, be sure to unplug the AC power cord for your safety and take care not to catch your feet on the cables.
- Disconnect the AC power cord from the AC power outlet before working on or moving the TV set.
- Keep the AC power cord away from heat sources.
- Unplug the AC power plug and clean it regularly. If the plug is covered with dust and it picks up moisture, its insulation may deteriorate, which could result in a fire.

Notes

- Do not use the supplied AC power cord on any other equipment.
- Do not pinch, bend, or twist the AC power cord excessively. The core conductors may be exposed or broken.
- Do not modify the AC power cord.
- Do not put anything heavy on the AC power cord.
- Do not pull on the AC power cord itself when disconnecting the AC power cord.
- Do not connect too many appliances to the same AC power outlet.
- Do not use a poor fitting AC power outlet.

Prohibited Usage

Do not install/use the TV set in locations, environments or situations such as those listed below, or the TV set may malfunction and cause a fire, electrical shock, damage and/or injuries.

Location:

Outdoors (in direct sunlight), at the seashore, on a ship or other vessel, inside a vehicle, in medical institutions, unstable locations, near water, rain, moisture or smoke.

Environment:

Places that are hot, humid, or excessively dusty; where insects may enter; where it might be exposed to mechanical vibration, near flammable objects (candles, etc). The TV shall not be exposed to dripping or splashing and no objects filled with liquids, such as vases, shall be placed on the TV.

Situation:

Do not use when your hands are wet, with the cabinet removed, or with attachments not recommended by the manufacturer. Disconnect the TV set from AC power outlet and antenna during lightning storms.

Broken pieces:

- Do not throw anything at the TV set. The screen glass may break by the impact and cause serious injury.
- If the surface of the TV set cracks, do not touch it until you have unplugged the AC power cord. Otherwise electric shock may result.

When not in use

- If you will not be using the TV set for several days, the TV set should be disconnected from the AC power for environmental and safety reasons.
- As the TV set is not disconnected from the AC power when the TV set is just turned off, pull the plug from the AC power outlet to disconnect the TV set completely.
- However, some TV sets may have features that require the TV set to be left in standby to work correctly.

For children

- Do not allow children to climb on the TV set.
- Keep small accessories out of the reach of children, so that they are not mistakenly swallowed.

If the following problems occur...

Turn off the TV set and unplug the AC power cord immediately if any of the following problems occur. Ask your dealer or Sony service centre to have it checked by qualified service personnel.

When:

- AC power cord is damaged.
- Poor fitting of AC power outlet.
- TV set is damaged by being dropped, hit or having something thrown at it.
- Any liquid or solid object falls through openings in the cabinet.

Precautions

Viewing the TV

- View the TV in moderate light, as viewing the TV in poor light or during long period of time, strains your eyes.
- When using headphones, adjust the volume so as to avoid excessive levels, as hearing damage may result.

LCD Screen

- Although the LCD screen is made with high-precision technology and 99.99% or more of the pixels are effective, black dots may appear or bright points of light (red, blue, or green) may appear constantly on the LCD screen. This is a structural property of the LCD screen and is not a malfunction.
- Do not push or scratch the front filter, or place objects on top of this TV set. The image may be uneven or the LCD screen may be damaged.
- If this TV set is used in a cold place, a smear may occur in the picture or the picture may become dark. This does not indicate a failure. These phenomena disappear as the temperature rises.
- Ghosting may occur when still pictures are displayed continuously. It may disappear after a few moments.
- The screen and cabinet get warm when this TV set is in use. This is not a malfunction.
- The LCD screen contains a small amount of liquid crystal. Mercury is sometimes contained depending on the kind of fluorescent tubes. Follow your local ordinances and regulations for disposal.

Handling and cleaning the screen surface/cabinet of the TV set

Be sure to unplug the AC power cord connected to the TV set from AC power outlet before cleaning.

To avoid material degradation or screen coating degradation, observe the following precautions.

- To remove dust from the screen surface/cabinet, wipe gently with a soft cloth. If dust is persistent, wipe with a soft cloth slightly moistened with a diluted mild detergent solution.
- Never use any type of abrasive pad, alkaline/acid cleaner, scouring powder, or volatile solvent, such as alcohol, benzene, thinner or insecticide. Using such materials or maintaining prolonged contact with rubber or vinyl materials may result in damage to the screen surface and cabinet material.
- When adjusting the angle of the TV set, move it slowly so as to prevent the TV set from moving or slipping off from its table stand.

Optional Equipment

Keep optional components or any equipment emitting electromagnetic radiation away from the TV set. Otherwise picture distortion and/or noisy sound may occur.

Overview of the remote

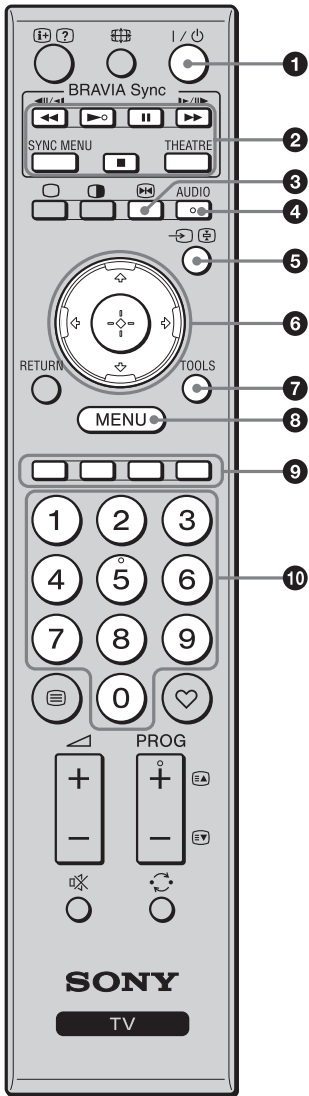

• The number 5, ►, PROG + and AUDIO buttons have tactile dots. Use the tactile dots as references when operating the TV.

1 I/⏻ – TV standby

Turns the TV on and off from standby mode.

2 BRAVIA Sync (page 21)

- ◀◀/▶▶/⏮/⏭: You can operate the BRAVIA Sync-compatible equipment or DIGITAL MEDIA PORT-compatible equipment that is connected to the TV.
- **SYNC MENU:** Displays the menu of connected HDMI CEC (Consumer Electronics Control) equipment which is supported. While viewing other input screens or TV programmes, “HDMI Device Selection” is displayed when the button is pressed.
- **THEATRE:** You can set Theatre Mode on or off. When Theatre Mode is set to on, the optimum audio output (if the TV is connected with an audio system using an HDMI cable) and picture quality for film videos are automatically set.

- Control for HDMI (BRAVIA Sync) is only available with the connected Sony equipment that has the BRAVIA Sync logo or is compatible with control for HDMI.
- If you turn the TV off, Theatre Mode is also turned off.

3 📺 – Picture freeze

Freezes the TV picture. Press once to display a frozen image with the current programme in a window. Press again to fill the screen with the frozen image. Press third time to return to the current programme.

Current programme (Location of the sub window can be moved by pressing ◀/▶/◀/▶.)



Frozen picture

- This function is not available for Twin Picture and PC input source.

4 AUDIO – Dual Sound (page 28)

5 ↵/📄 – Input select / Text hold

- Displays the connected equipment list and selects the input source (page 18).
- In Text mode: Holds the current page.

6 ⬆/⬇/⬅/➡/⬆ – Item select / OK

- Selects or adjusts items.
- Confirms selected items.

7 TOOLS (page 15)

8 MENU

Displays or cancels the menu.

9 Coloured buttons

In Text mode: Accesses the corresponding coloured Fastext menu quickly and easily. The Fastext feature can be used only when the Fastext broadcast is available.

10 Number buttons

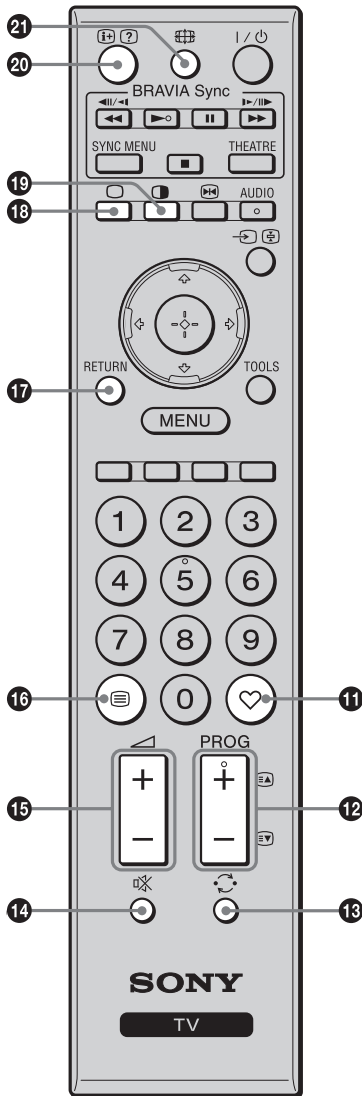

- Selects channels. For channel numbers 10 and above, enter the second digit quickly (page 33).
- In Text mode: Enters the three digit page number to select the page.



- 11** – **Favourite list**
Displays the Favourite list that you have specified (page 23).
- 12** **PROG +/-** / /
 - Selects the next (+) or previous (-) channel.
 - In Text mode: Selects the next () or previous () page.
- 13** – **Previous channel**
Returns to the previous channel watched (for more than five seconds).
- 14** – **Mute**
Press to mute the sound. Press again to restore the sound.
 - In standby mode, if you want to turn on the TV without sound, press this button.
- 15** +/- – **Volume**
Adjusts volume.
- 16** – **Text**
In Text mode: Displays Text broadcast: Text → Text over the TV picture (mix mode) → No Text (exit the Text service).
 - Text language displays can be either English, Persian or French depending on your broadcast signal.
- 17** **RETURN**
Returns to the previous screen of any displayed menu.
- 18** – **TV mode**
Exit Text mode, or switches to a TV display when displaying external input.
- 19** – **Twin Picture / PIP (page 20)**
Displays two pictures simultaneously.
- 20** / – **Info / Text reveal**
 - Displays information. Press once to display current channel number and screen mode. Press again to display clock information. Press third time to remove the display from the screen.
 - In Text mode: Reveals hidden information (e.g. answers to a quiz).
- 21** – **Wide Mode**
Changes the picture size. Press repeatedly to select the desired wide mode.

Continued

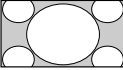
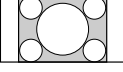
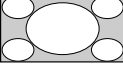
For TV, Video, HD/DVD, HDMI or DIGITAL MEDIA PORT (except PC input)

<p>Wide Zoom*</p> 	<p>Enlarges the centre portion of the picture. The left and right edges of the picture are stretched to fill the 16:9 screen.</p>
<p>Normal</p> 	<p>Displays the 4:3 picture in its original size. Side bars are shown to fill the 16:9 screen.</p>
<p>Full</p> 	<p>Stretches the 4:3 picture horizontally, to fill the 16:9 screen.</p>
<p>Zoom*</p> 	<p>Displays cinemascopic (letter box format) broadcasts in the correct proportions.</p>

* Parts of the top and bottom of the picture may be cut off.

✎ • You cannot select “Normal” for HD signal source pictures.

For PC Input

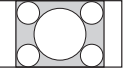
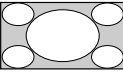
<p>Full 1</p> 	<p>Stretches the original picture to fill the screen vertically.</p>
<p>Full 2</p> 	<p>Stretches the Full 1 picture horizontally to fill the 16:9 screen.</p>

Using the Tools menu

Press **TOOLS** enables you to access various viewing options and change/make adjustments according to the source and screen mode. The options displayed vary depending on the input source.

Viewing TV programme

Options	Description
Picture Mode	See page 26.
Sound Mode	See page 27.
Intelligent Picture	See page 33.
MPEG Noise Reduction	See page 26.
Speaker	See page 30.
Add to Favourites	You can add the current channel to the favourite list.
Sleep Timer	See page 31.
Power Saving	See page 31.

Viewing connected equipment

Options	Description
Picture Mode (except PC input mode)	See page 26.
Display Mode (in PC input mode only)	See page 26.
Sound Mode	See page 27.
MPEG Noise Reduction (except PC input mode)	See page 26.
Speaker	See page 30.
Twin Picture (except PC and DMPORT input mode)	See page 20.
PIP (in PC input mode only)	See page 20.
Single Picture (in Twin Picture and PIP mode only)	See page 20.
Audio Swap (in PIP mode only)	See page 20.
Auto Adjustment (in PC input mode only)	See page 32.
Horizontal Shift (in PC input mode only)	See page 32.
Sleep Timer (except PC input mode)	See page 31.
Power Saving	See page 31.
Device Control [in HDMI input mode (except HDMI PC input only)]	Displays the menu screen to operate the connected HDMI-compatible equipment.
Device Control (Menu) (in DMPORT input mode only)	If the connected DIGITAL MEDIA PORT-compatible equipment has the operation menu, displays it directly.
Control Panel (in DMPORT input mode only)	Displays the control panel to operate the connected DIGITAL MEDIA PORT-compatible equipment.

Overview of the TV buttons and indicators

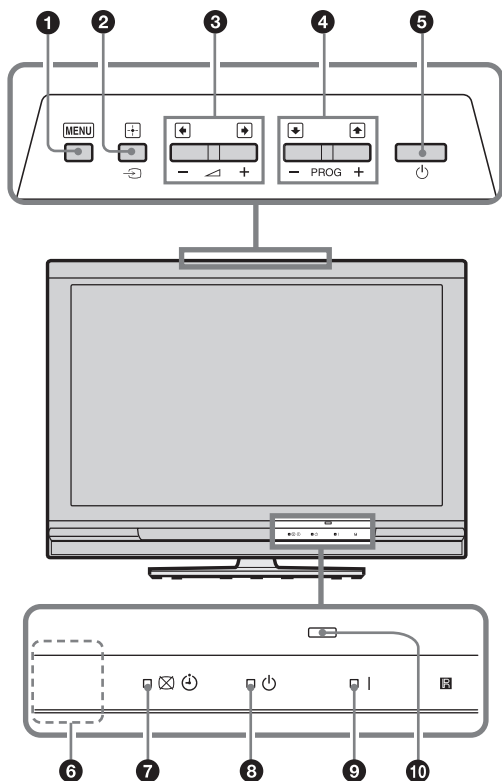

- 1 MENU**
 Displays or cancels the menu.
- 2 – Input select / OK**
 - Displays the connected equipment list and selects the input source (page 18).
 - In TV menu: Selects the menu or option, and confirms the setting.
- 3 +/- /**
 - Increases (+) or decreases (-) the volume.
 - In TV menu: Moves through the options right () or left (.
- 4 PROG +/- / /**
 - Selects the next (+) or previous (-) channel.
 - In TV menu: Moves through the options up () or down (.
- 5 – Power**
 Turns the TV on or off.
 - To disconnect the TV from the AC power completely, pull the plug from the AC power outlet.
- 6 Light sensor (page 31)**
 Do not put anything over the sensor, as its function may be affected.
- 7 /**
 - Lights up in green when the picture is turned off (page 31).
 - Lights up in amber when the timer is set (page 31).
- 8 – Standby indicator**
 Lights up in red when the TV is in standby mode.
- 9 – Power indicator**
 - Lights up in green when the TV is turned on.
 - Flashes while the remote is being operated.
- 10 – Remote sensor**
 Receives IR signals from the remote.

Connecting optional equipment

You can connect a wide range of optional equipment to your TV.

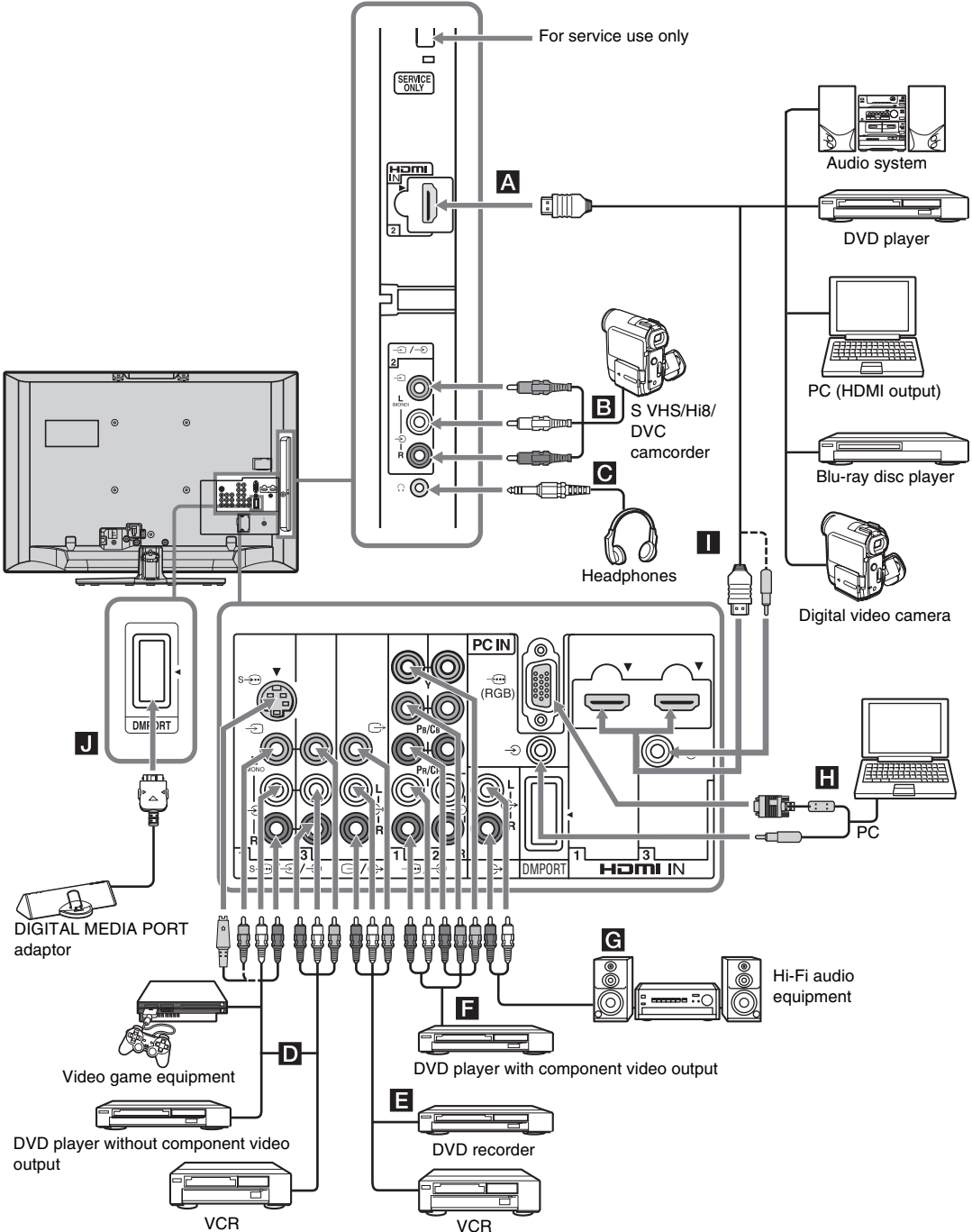

Viewing pictures from the connected equipment

Turn on the connected equipment, then press / to display the connected equipment list. Press / to select the desired input source, then press . (The highlighted item is selected if 2 seconds pass without any operation after pressing /.) When the input source is set to “Skip” in the “Video Labels” under the “AV Set-up” menu (page 29), that input does not appear in the list.

- Press / on the top edge of the TV to display the connected equipment list and select the desired input source. You can also press / to select the desired input source. Then wait for 2 seconds to display the selected input source.

Jacks/ Input symbol on screen	Description
A HDMI IN 2 I HDMI IN 1 or 3 HDMI 1 or HDMI 2 or HDMI 3	<p>Connect to the HDMI IN 1, 2 or 3 jack if the equipment has an HDMI jack. The digital video and audio signals are input from the equipment. In addition, when you connect the equipment that is compatible with control for HDMI, communication with the connected equipment is supported. Refer to page 30 to set-up this communication. If the equipment has a DVI jack, connect the DVI jack to the HDMI IN 3 jack through a DVI - HDMI adaptor interface (not supplied), and connect the equipment's audio out jack to the audio in jack in the HDMI IN 3 jack.</p> <p> • The HDMI jacks only support the following video inputs: 480i, 480p, 576i, 576p, 720p (50/60 Hz), 1080i (50/60 Hz), 1080p (50/60 Hz) and 1080/24p.</p> <ul style="list-style-type: none"> • Be sure to use only an HDMI cable that bears the HDMI logo (recommended Sony HDMI cable). • When connecting an audio system with HDMI jack, be sure to also connect to the audio output jacks (refer G in page 17) to listen to the sound from the TV on audio system.
B 2, and 2 Video 2	<p>Connect to the video jack 2, and the audio jacks 2. If you connect mono equipment, connect to the L(MONO) jack .</p>
C	<p>Connect to the jack to listen to sound from the TV on headphones.</p>
D 1 or 1 or 3, and 1 or 3 Video 1 or Video 1 or Video 3	<p>Connect to the S video jack 1 or the video jack 1 or 3, and the audio jacks 1 or 3. To avoid picture noise, do not connect the camcorder to the video jack 1 and the S video jack 1 at the same time. If you connect mono equipment, connect to the L(MONO) jack 1 or 3.</p>
E	<p>Connect to the video output jack to record the image from the TV. Connect to the audio output jacks to record the sound from the TV on DVD recorder or VCR. To turn off the sound of the TV speakers, set “Speaker” to “Audio System” (page 30). If you connect mono equipment, connect to the L jack .</p> <p> • The monitor output jacks cannot support HD/DVD, HDMI and PC signals source pictures, also digital audio signal for sound.</p>
F /1 or 2 HD/DVD 1 or HD/DVD 2	<p>Connect to the component jacks and the audio jacks /1 or 2. For better picture quality, component connection is recommended if your DVD player has a component video output.</p>
G	<p>Connect to the audio output jacks to listen to the sound from the TV on Hi-Fi audio equipment. To turn off the sound of the TV speakers, set “Speaker” to “Audio System” (page 30).</p>
H PC IN (RGB)/ PC	<p>Connect to the PC IN (RGB) jack and the audio jack . It is recommended to use a PC cable with ferrite core.</p>

Jacks/ Input symbol on screen	Description
J DMPORT DMPORT	<p>You can play audio or video (optional cable required) of a portable audio player that is connected to the TV using a DIGITAL MEDIA PORT adaptor.</p> <p>Depending on the connected DIGITAL MEDIA PORT adaptor, you can operate the connected equipment using the TV as follows;</p> <ul style="list-style-type: none"> - Using the remote of the TV: . - Using the Tools menu function: Press TOOLS, and select "Control Panel". <p> • This function may be not available for certain connected equipment. Refer to the instruction manual of the connected equipment for details.</p> <ul style="list-style-type: none"> • Do not connect or disconnect a DIGITAL MEDIA PORT adaptor while the TV is turned on. • The connected equipment is not charged when the TV is turned off or in standby mode.

Viewing Twin Picture

You can view two pictures (external input and TV programme) on the screen simultaneously. Connect the optional equipment (page 17), and make sure that images from the equipment appear on the screen (page 18).

- 1 Press **⏏**.
Two pictures are displayed simultaneously.



Twin Picture Availability

In Left Window	In Right Window
HD/DVD 1	
HD/DVD 2	TV programme
HDMI 1 (except PC input mode)	
HDMI 2 (except PC input mode)	
HDMI 3 (except PC input mode)	
Video 1 or S Video 1	
Video 2	No picture
Video 3	

- 2 Press **↔** to select active picture.
- 3 Press number buttons or **PROG +/-** to select the TV channel.

To return to single picture mode

Press **⊕** or **RETURN**.

- This function is not available when displaying a PC input or DIGITAL MEDIA PORT input.
- You cannot change the size of the pictures.
- The picture and sound from the monitor output jacks **↔** (refer **E** in page 17) will follow the left picture (Video 1/S Video 1/Video 2/Video 3 only). However, if audio output jacks **↔** (refer **G** in page 17) are connected, the sound will follow TV speaker.
- In Twin Picture mode, as picture size reduced, this may decrease picture smoothness.
- The picture framed in grey is audible. You can switch the audible picture by pressing **↔**.
- You can also use the Twin Picture feature by selecting “Twin Picture” from the Tools menu.

Viewing PIP (Picture in Picture)

You can view two pictures (PC input and TV programme) on the screen simultaneously. Connect a PC (page 17), and make sure that images from a PC appear on the screen (page 18).

- 1 Press **⏏**.
Two pictures are displayed simultaneously.



PIP Availability

In Main Window	In Sub Window
PC	
HDMI 1 (in PC input mode only)	TV programme
HDMI 2 (in PC input mode only)	
HDMI 3 (in PC input mode only)	

- 2 Press number buttons or **PROG +/-** to select the TV channel.

To return to single picture mode

Press **RETURN**.

- You cannot display resolutions higher than WXGA (1360 × 768 pixels).
- “Power Management” is not available in PIP mode (page 32).
- The sound will follow TV speaker when audio output jacks **↔** (refer **G** in page 17) are connected.
- In PIP mode, as picture size reduced, this may decrease picture smoothness.
- You can switch the audible picture by selecting “Audio Swap” from the Tools menu.
- You can also use the PIP feature by selecting “PIP” from the Tools menu.



Using BRAVIA Sync (Control for HDMI)

The control for HDMI function enables the TV to communicate with the connected equipment that is compatible with the function, using HDMI CEC (Consumer Electronics Control).

For example, by connecting Sony equipment that is compatible with control for HDMI (with HDMI cables), you can control them together.

Be sure to connect the compatible equipment correctly, and make the necessary settings.









To connect the equipment that is compatible with control for HDMI

Connect the compatible equipment and the TV with an HDMI cable. When connecting an audio system, in addition to the HDMI cable, be sure to also connect to the audio output jacks  (refer  in page 17) to listen to the sound from the TV on audio system. For details, see page 17.

To make the control for HDMI settings

The control for HDMI settings must be set on both the TV side and the connected equipment side. See “HDMI Set-up” on page 30 for the TV side settings. See the operating instructions of the connected equipment for setting details.

Control for HDMI

- Automatically turns the connected equipment off when you turn the TV off.
- Automatically turns the TV on and switches the input to the connected equipment when the equipment starts to play.
- If you turn on a connected audio system while the TV is on, the sound output switches from the TV speaker to the audio system.
- Adjusts the volume () and mutes the sound () of a connected audio system.
- You can operate the connected Sony equipment that has the BRAVIA Sync logo by the TV remote by pressing:
 - /// to operate the connected equipment directly.
 - SYNC MENU to display the menu of the connected HDMI CEC equipment which is supported on the screen.
After displaying the menu, you can operate the menu screen by using / and .
 - TOOLS to display “Device Control”, then select options from “Menu”, “Options”, and “Content List” to operate the equipment.

Refer to the instruction manual of the equipment for available control.

Navigating through menus

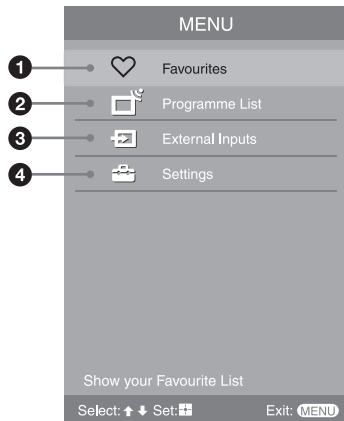
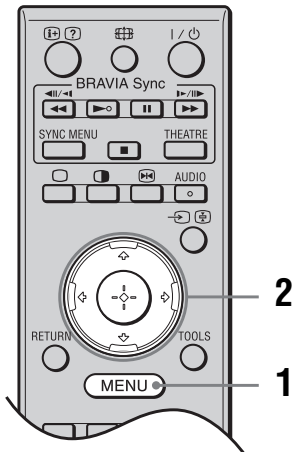

“MENU” allows you to enjoy various convenient features of this TV. You can easily select channels or inputs sources and change the settings for your TV.

- 1 Press MENU.
- 2 Press \uparrow/\downarrow to select an option, then press \oplus .

To exit the menu, press MENU.

1 Favourites

Displays the favourite list (page 23).

- To watch the desired channel, select the favourite channel number, then press \oplus .
- To add the current channel to the favourite list, select “Add to Favourites”. When the favourite list is full, select “Edit Favourites” to remove any channel from your list and try again (page 23).

2 Programme List

Displays available TV channels.

- To watch the desired channel, select the channel, then press \oplus .
- To assign a label to a channel, select “Edit Programme Labels”, then see page 33.

3 External Inputs

Selects equipment connected to your TV.

- To watch the desired external input, select the input source, then press \oplus .
- To assign a label to an external input, select “Edit Video Labels”, then see page 29.
- To select the equipment that is compatible with control for HDMI, select “HDMI Device Selection”.

4 Settings

Displays the “Settings” menu where most of the advanced settings and adjustments are performed.

For details about settings, see page 24 to 25.

Using the Favourite List

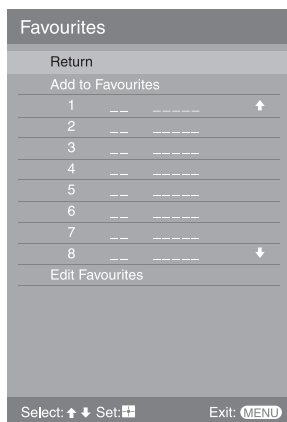

Favourite List

The Favourite feature lets you select programmes from a list of up to 16 favourite channels that you specify.

- 1** Press MENU.
- 2** Press \uparrow/\downarrow to select “Favourites”, then press \oplus .
- 3** Perform the desired operation as shown in the following table or displayed on the screen.

To	Do this
Watch a channel	Press \uparrow/\downarrow to select the channel number, then press \oplus .
Turn off the Favourite list	Press RETURN to return to the previous screen. Press MENU or \heartsuit to exit the menu.
Add a current channel to the Favourite list	Press \uparrow/\downarrow to select “Add to Favourites”, then press \oplus .
Remove a channel from the Favourite list	Press \uparrow/\downarrow to select “Edit Favourites”, then press \oplus . The “Favourite Set-up” screen appears. For details, see “Favourite Set-up” on page 33.

Settings adjustment

You are able to change the settings of your TV from “Settings” menu.

- 1 Press MENU. Press \uparrow/\downarrow to select “Settings”, then press \oplus .
- 2 Press \uparrow/\downarrow to select a menu icon, then press \oplus .
- 3 Press $\uparrow/\downarrow/\leftarrow/\rightarrow$ to select an option or adjust a setting, then press \oplus .

The following is an overview of the items that can be adjusted.

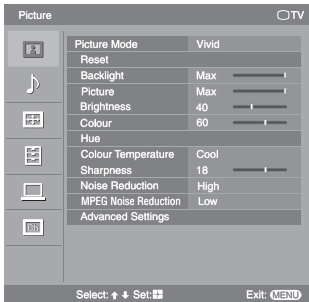

Picture menu (page 26)

“Picture Mode”: “Vivid” \rightarrow “Standard” \rightarrow “Cinema” (except PC input mode)

“Display Mode”: “Video” \rightarrow “Text” (in PC input mode only)

“Reset”

“Backlight”

“Picture”

“Brightness”

“Colour”

“Hue”

“Colour Temperature”: “Cool” \rightarrow “Neutral” \rightarrow “Warm 1” \rightarrow “Warm 2”

“Sharpness”

“Noise Reduction”: “High” \rightarrow “Medium” \rightarrow “Low” \rightarrow “Off”

“MPEG Noise Reduction”: “High” \rightarrow “Medium” \rightarrow “Low” \rightarrow “Off”

“Advanced Settings”: “Adv. Contrast Enhancer”, “Live Colour”

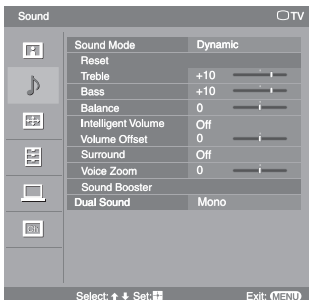

Sound menu (page 27)

“Sound Mode”: “Dynamic” \rightarrow “Standard” \rightarrow “Clear Voice”

“Reset”

“Treble”

“Bass”

“Balance”

“Intelligent Volume”: “On” \rightarrow “Off”

“Volume Offset”

“Surround”: “S-FORCE Front Surround” \rightarrow “Simulated Stereo” \rightarrow “Off”

“Voice Zoom”

“Sound Booster”: “High” \rightarrow “Low” \rightarrow “Off”

“Dual Sound”

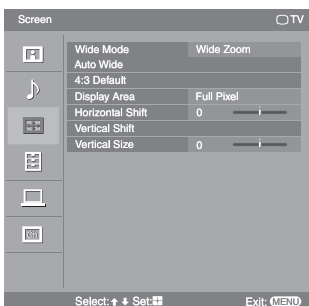

Screen menu (page 28)

“Wide Mode”: “Wide Zoom” \rightarrow “Normal” \rightarrow “Full” \rightarrow “Zoom”

“Auto Wide”: “On” \rightarrow “Off”

“4:3 Default”: “Wide Zoom” \rightarrow “Normal” \rightarrow “Off”

“Display Area”: “Full Pixel” \rightarrow “Normal” (KLV-46V400A/KLV-40V400A only)

“Horizontal Shift”

“Vertical Shift”

“Vertical Size”

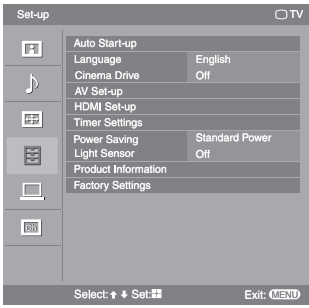

Set-up menu (page 29)

“Auto Start-up”

“Language”: “English” → “中文” (Chinese) → “ภาษาไทย” (Thai) → “عربي” (Arabic) → “فارسی” (Persian)

“Cinema Drive”: “Auto” → “Off”

“AV Set-up”: “Video Labels”, “Auto S Video”, “Speaker”, “Audio Out”, “Colour System”

“HDMI Set-up”: “Control for HDMI”, “Auto Devices Off”, “Auto TV On”, “Device List Update”, “HDMI Device List”

“Timer Settings”: “Sleep Timer”, “On Timer”, “Clock Set”

“Power Saving”: “Standard Power” → “Reduced Power” → “Picture Off”

“Light Sensor”: “On” → “Off”

“Product Information”

“Factory Settings”

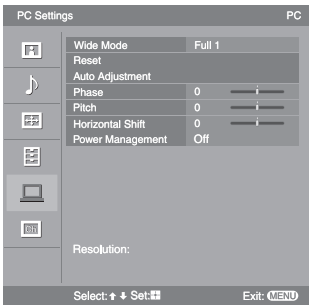

PC Settings menu (page 32)

“Wide Mode”: “Full 1” → “Full 2”

“Reset”

“Auto Adjustment”

“Phase”

“Pitch”

“Horizontal Shift”

“Power Management”: “On” → “Off”

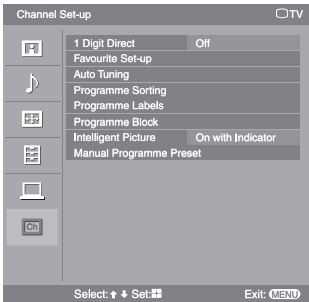

Channel Set-up menu (page 33)

“1 Digit Direct”: “On” → “Off”

“Favourite Set-up”

“Auto Tuning”

“Programme Sorting”

“Programme Labels”

“Programme Block”

“Intelligent Picture”: “On with Indicator” → “On” → “Off”

“Manual Programme Preset”: “Programme”, “TV System”, “VHF Low”/ “VHF High”/ “UHF”, “Label”, “AFT”, “Audio Filter”, “Skip”, “Colour System”, “Signal Booster”, “Signal Level”

• The options you can adjust vary depending on the situation. Unavailable options are greyed out or not displayed.







Picture menu

Press MENU and select “Settings”. Make sure the “Picture” icon () is selected, then press \oplus .

Picture Mode	Selects the picture mode except for PC input source. “Vivid” : For enhanced picture contrast and sharpness. “Standard” : For standard picture. Recommended for home entertainment. “Cinema” : For optimum picture quality of film videos.
Display Mode	Selects the display mode for PC input source. “Video” : For video images. “Text” : For text, charts or tables. <i>ℳ</i> • The options displayed vary depending on the input source.
Reset	Resets all the “Picture” settings except “Picture Mode” and “Display Mode” to the factory settings.
Backlight	Adjusts the brightness of the backlight.
Picture	Increases or decreases picture contrast.
Brightness	Brightens or darkens the picture.
Colour	Increases or decreases colour intensity.
Hue	Increases or decreases the green tones and red tones. <i>ℳ</i> • “Hue” can only be adjusted for an NTSC colour system (e.g. U.S.A. video tapes). • “Hue” is not available for PC input, component and HDMI input source.
Colour Temperature	Adjusts the whiteness of the picture. “Cool” : Gives the white colours a blue tint. “Neutral” : Gives the white colours a neutral tint. “Warm 1”/“Warm 2” : Gives the white colours a red tint. “Warm 2” gives a redder tint than “Warm 1”. <i>ℳ</i> • “Warm 1” and “Warm 2” are not available when “Picture Mode” is set to “Vivid”.
Sharpness	Sharpens or softens the picture.
Noise Reduction	Reduces the picture noise (snowy picture) in a weak broadcast signal. “High”/“Medium”/“Low” : Modifies the effect of the noise reduction. “Off” : Turns off the “Noise Reduction” feature.
MPEG Noise Reduction	Reduces the picture noise in MPEG-compressed video. Choose either “High”, “Medium”, “Low” or “Off”.
Advanced Settings	Customises the “Picture” function in more detail. When you set “Picture Mode” to “Standard” or “Cinema”, you can set/change these settings. “Adv. Contrast Enhancer” : Automatically adjusts “Backlight” and “Picture” to the most suitable settings judging from the brightness of the screen. This setting is especially effective for dark images scenes. It will increase the contrast distinction of the darker picture scenes. “Live Colour” : Makes colours more vivid. <i>ℳ</i> • “Advanced Settings” is not available for a PC input source or when “Picture Mode” is set to “Vivid”.

Sound menu

Press MENU and select “Settings”. Press  to select the “Sound” icon () , then press .

Sound Mode	“ Dynamic ”: Enhances treble and bass. Recommended for home entertainment. “ Standard ”: For standard sound. “ Clear Voice ”: Makes voice sound clearer.
Reset	Resets all the “Sound” settings except “Sound Mode” and “Dual Sound” to the factory settings.
Treble	Adjusts higher-pitched sounds.
Bass	Adjusts lower-pitched sounds.
Balance	Emphasises left or right speaker balance.
Intelligent Volume	Keeps a constant volume level even when volume level gaps occur (e.g. adverts tend to be louder than programmes).
Volume Offset	Adjusts the volume level of the current input relative to other inputs.
Surround	“ S-FORCE Front Surround ”: Available for normal stereo broadcast and 5.1ch broadcast surround audio, and the audio input from connected equipment. “ Simulated Stereo ”: Adds a surround-like effect to mono programmes. “ Off ”: Converts and reproduces 5.1ch and other broadcast surround audio as normal stereo audio (2ch). Reproduces the original audio of other broadcasts as it is.
Voice Zoom	Adjusts the clarity of human voices. For example, if the voice of a news announcer is indistinct, you can turn up this setting to make the voice clearer. Conversely, if you are watching a sports programme, you can turn down this setting to soften the voice of the commentator.
Sound Booster	Gives sound more impact by compensating for phase effects in speakers. Choose either “High”, “Low” or “Off”.  • “Sound Booster” is available when “Sound Mode” is set to “Standard”.

Dual Sound

Selects the sound from the speaker for a stereo or bilingual broadcast. The selection varies, depending on the Broadcasting.

Broadcasting	Selection
NICAM stereo	Stereo (stereo sound) Mono (regular sound)
NICAM bilingual	Main (main sound) Sub (sub sound) Mono (regular sound)
NICAM monaural	Main (main sound) Mono (regular sound)
A2 (German) stereo	Stereo (stereo sound) Mono (regular sound)
A2 (German) bilingual	Main (main sound) Sub (sub sound)

- If the signal is very weak, the sound becomes monaural automatically.
- If the stereo sound is noisy when receiving a NICAM programme, select “Mono”. The sound becomes monaural, but the noise is reduced.
- The “Dual Sound” setting is memorized for each programme position.
- You cannot receive a stereo broadcast signal when “Mono” is selected for the programme position.
- You cannot receive stereo or dual sound when “Low” or “High” is selected in “Audio Filter” (page 34).
- NICAM is receivable in following countries/regions. Hong Kong, Singapore, New Zealand, Malaysia, Thailand, etc.
- A2 (German) is receivable in following countries/regions. Australia, Malaysia, Thailand, etc.
- If you select other equipment connected to the TV, set “Dual Sound” to “Stereo”, “Main” or “Sub”. However, when the external equipment connected to the HDMI jack is selected, this is fixed to “Stereo”, except HDMI IN 3 with DVI analogue sound input.



Screen menu

Press MENU and select “Settings”. Press \uparrow/\downarrow to select the “Screen” icon () , then press \oplus .

- “Screen” menu is not available when receiving PC signal. When receiving PC signal, you can use “PC Settings” menu to perform related settings (page 32).

Wide Mode

For details about the wide mode, see page 14.

Auto Wide

Automatically changes the wide mode according to the input signal from an external equipment. To keep your setting, select “Off”.

- “Auto Wide” is not available when watching TV programmes.
- Even if “Auto Wide” is set to “On” or “Off”, you can always modify the format of the screen by pressing ⏏ repeatedly.

4:3 Default

Selects the default screen mode for use with 4:3 broadcasts.

“**Wide Zoom**”: Displays conventional 4:3 broadcasts with an imitation wide screen effect.



“**Normal**”: Displays conventional 4:3 broadcasts in the correct proportions.

“**Off**”: Keeps the current “Wide Mode” setting when the channel or input is changed.

- “4:3 Default” is available only if “Auto Wide” is set to “On”.
- “4:3 Default” is not available when watching TV programmes or for a HD input signal.

Display Area (KLV-46V400A/ KLV-40V400A only)	Adjusts the screen area for displaying the picture. “Full Pixel” : Displays the picture for 1080/50i, 1080/60i, 1080/50p and 1080/60p sources (HDMI or component input only) or 1080/24p sources (HDMI input only) in the original size when parts of the picture are cut off. “Normal” : Displays the recommended picture area.  • “Display Area” is available only when “Wide Mode” is set to “Full”.
Horizontal Shift	Adjusts the horizontal position of the picture.
Vertical Shift	Adjusts the vertical position of the picture when “Wide Mode” is set to “Wide Zoom” or “Zoom”.
Vertical Size	Adjusts the vertical size of the picture when “Wide Mode” is set to “Wide Zoom” or “Zoom”.

Set-up menu



Press MENU and select “Settings”. Press  to select the “Set-up” icon (), then press .

Auto Start-up	Starts the initial set-up procedure. Usually, you do not need to do this operation because it was done when the TV was first installed (page 7). However, this option allows you to repeat the process (e.g. to retune the TV after moving house, or to search for new channels that have been launched by broadcasters).
Language	Selects the language in which the menus are displayed.
Cinema Drive	Provides smoother picture movement when playing DVD or VCR images taken on film, reducing picture blur and graininess. “Auto” : Provides smoother picture movement than the original film video. Use this setting for standard use. “Off” : Turns off the “Cinema Drive” feature.  • If the image contains irregular signals or too much noise, “Cinema Drive” will be automatically turned off even if “Auto” is selected. • “Cinema Drive” is not available for a PC input source.

AV Set-up

Video Labels

Assigns a name to any equipment connected to the side and rear jacks. The name will be displayed briefly on the screen when the equipment is selected. You can skip input signals from connected equipment that you do not want displayed on the screen.

1 Press  to select the desired input source, then press .



2 Press  to select the desired option below, then press .

Equipment labels: Uses one of the preset labels to assign a name to connected equipment.

“Edit”: Creates your own label. Follow steps 2 to 4 of “Programme Labels” (page 33).

“Skip”: Skips an unnecessary input source.

Auto S Video

Selects the input signal from S video jack  1 when  1 jacks are both connected.

“On”: Switches automatically between the S video jack and the composite video jacks depending on the cable connection.

“Off”: Activates the composite video jacks.

Continued

Speaker

Turns on/off the TV's internal speakers.

“TV Speaker”: The TV speakers are turned on in order to listen to the TV's sound through the TV speakers.

“Audio System”: The TV speakers are turned off in order to listen to the TV's sound only through your external audio equipment connected to the audio output jacks. You can also turn on the connected equipment that is compatible with control for HDMI, after making the appropriate settings of control for HDMI.

 • All items in “Sound” menu except “Dual Sound” are not available when “Speaker” is set to “Audio System”.

Audio Out

“Variable”: The audio output from your audio system can be controlled by the TV's remote.

“Fixed”: The audio output of the TV is fixed. Use your audio receiver's volume control to adjust the volume (and other audio settings) through your audio system.

 • “Audio Out” is not available for audio system connected to the TV using the HDMI jacks.

Colour System

Selects the colour system (“Auto”, “PAL”, “SECAM”, “NTSC3.58”, “NTSC4.43” or “PAL60”) according to the composite video signal from the input source.

HDMI Set-up

Allows the TV to communicate with equipment that is compatible with the control for HDMI function, and connected to the HDMI jacks of the TV. Note that communication settings must also be made on the connected equipment.

Control for HDMI

Sets whether or not to link the operations of the TV and the connected equipment that is compatible with control for HDMI. When set to “On”, the following menu items can be performed.

If the specific Sony equipment that is compatible with control for HDMI is connected, this setting is applied to the connected equipment automatically when the “Control for HDMI” is set to “On” using the TV.

Auto Devices Off

When this is set to “On”, the connected equipment that is compatible with control for HDMI turns off when you turn off the TV.

Auto TV On

When this is set to “On”, the TV turns on when you turn on the connected equipment that is compatible with control for HDMI.

Device List Update

Creates or updates the “HDMI Device List”. Up to 11 compatible equipment items can be connected, and up to 5 equipment items can be connected to a single jack. Be sure to update the “HDMI Device List” when you change the connections or settings. If the specific Sony equipment that is compatible with control for HDMI is connected, this setting is applied to the connected equipment automatically when the “Device List Update” is executed on the TV.

HDMI Device List

Displays a list of connected equipment that is compatible with control for HDMI.

 • You cannot use “Control for HDMI” and “Device List Update” if the TV operations are linked to the operations of an audio system that is compatible with control for HDMI.

Timer Settings

Sets the timer to turn on/off the TV.

Sleep Timer

Sets a period of time after which the TV automatically switches itself into standby mode.

When the “Sleep Timer” is activated, the ☺ (Timer) indicator on the TV front panel lights up in amber.

- ☺ • If you turn off the TV and turn it on again, “Sleep Timer” is reset to “Off”.
- A notification message appears on the screen one minute before the TV switches to standby mode.

On Timer

Sets the timer to turn on the TV from standby mode.

“**Day**”: Selects the day on which you want to activate the “On Timer”.

“**Time**”: Sets the time to turn on the TV.

“**Duration**”: Selects the time period after which the TV automatically switches to standby mode again.

Clock Set

Allows you to adjust the clock manually.

Power Saving

Selects the power saving mode to reduce the power consumption of the TV.

Choose either “Standard Power”, “Reduced Power” or “Picture Off”.

When “Picture Off” is selected, the picture is turned off and the ☒ (Picture Off) indicator on the TV front panel lights up in green. The sound remains unchanged.

Light Sensor

“**On**”: Automatically optimises the picture settings according to the ambient light in the room.

“**Off**”: Turns off the “Light Sensor” feature.

- ☞ • Be sure not to put anything over the sensor, as its function may be affected.
-

Product Information

Displays your TV’s product information.

Factory Settings

Resets all settings to factory settings other than “Programme Block”, “Favourites” settings, and the programme preset data. After completing this process, the initial set-up screen is displayed the next time you turn on the TV. Completing auto tuning in initial set-up will reset these settings. To keep them, select “Cancel” in the auto tuning confirmation dialog.

- ☞ • Be sure not to turn the TV off during this period (it takes about 30 seconds) or press any buttons.
-



PC Settings menu

Press MENU and select “Settings”. Press \updownarrow to select the “PC Settings” icon (), then press \oplus .

Wide Mode	Selects a screen mode for displaying input from your PC, see page 14. “Full 1” : Enlarges the picture to fill the display area, keeping its original horizontal-to-vertical aspect ratio. “Full 2” : Enlarges the picture to fill the display area.
Reset	Resets all the “PC Settings” except “Wide Mode” and “Power Management” to the factory settings.
Auto Adjustment	Automatically adjusts the display position and phase of the picture when the TV receives an input signal from the connected PC.  • “Auto Adjustment” may not work well with certain input signals. In such cases, manually adjust “Phase” and “Horizontal Shift”.
Phase	Adjusts the phase when the screen flickers.
Pitch	Adjusts the pitch when the picture has unwanted vertical stripes.
Horizontal Shift	Adjusts the horizontal position of the picture.
Power Management	Switches the TV to standby mode if no signal is received for 30 seconds.

PC Input Signal Reference Chart for supported signals and “Resolution:” value displayed

Signals	Horizontal (Pixel)	Vertical (Line)	Horizontal frequency (kHz)	Vertical frequency (Hz)	Standard
VGA	640	480	31.5	60	VGA
	640	480	37.5	75	VESA
	720	400	31.5	70	VGA-T
SVGA	800	600	37.9	60	VESA Guidelines
	800	600	46.9	75	VESA
XGA	1024	768	48.4	60	VESA Guidelines
	1024	768	56.5	70	VESA
	1024	768	60	75	VESA
WXGA	1280	768	47.4	60	VESA
	1280	768	47.8	60	VESA
	1360	768	47.7	60	VESA

-  • This TV’s PC input does not support Sync on Green or Composite Sync.
- This TV’s PC input does not support interlaced signals.
- If input signal is not shown in above chart, then this signal may not be displayed properly or cannot be displayed according to your settings.
- When connecting a personal computer to HDMI IN 1, 2 or 3 jack, your TV can only display the signals (boldfaced) in the above chart with a 60 Hz vertical frequency.
-  • For the best picture quality, it is recommended to use the signals (boldfaced) in the above chart with a 60 Hz vertical frequency from a personal computer. In plug and play, signals with a 60 Hz vertical frequency will be selected automatically.



Channel Set-up menu

Press MENU and select “Settings”. Press \uparrow/\downarrow to select the “Channel Set-up” icon (), then press \oplus .

1 Digit Direct

When “1 Digit Direct” is set to “On”, you can select a channel using one preset number button (0 - 9) on the remote.

- ✎ • When “1 Digit Direct” is set to “On”, you cannot select channel numbers 10 and above entering two digits using the remote.

Favourite Set-up

Allows you to set your favourite channels by assigning the desired channel numbers.

1 Press \uparrow/\downarrow to select your favourite channel number, then press \oplus .

2 Press \uparrow/\downarrow to select your desired channel, then press \oplus .

To reset the Favourite channels

Select “_ _”, then press \oplus .

Repeat the procedure above to set other favourite channels.

Auto Tuning

Tunes in all the available channels.

This option allows you to retune the TV after moving house, or to search for new channels that have been launched by broadcasters.

Programme Sorting

Changes the order in which the channels are stored on the TV.

1 Press \uparrow/\downarrow to select the channel you want to move to a new position, then press \oplus .

2 Press \uparrow/\downarrow to select the new position for your channel, then press \oplus .

Programme Labels

Assigns a channel name of your choice up to five letters or numbers. The name will be displayed briefly on the screen when the channel is selected.

1 Press \uparrow/\downarrow to select the channel you want to name, then press \oplus .

2 Press \uparrow/\downarrow to select the desired letter or number (“_” for a blank space), then press \Rightarrow .

If you input a wrong character

Press \Leftarrow/\Rightarrow to select the wrong character. Then, press \uparrow/\downarrow to select the correct character.

To delete all the characters

Select “Reset”, then press \oplus .

3 Repeat the procedure in step 2 until the name is completed.

4 Select “OK”, then press \oplus .

Programme Block

Blocks an individual channel from being watched.

1 Press \uparrow/\downarrow to select the channel you want to block, then press \oplus .

2 Press \uparrow/\downarrow to select “Block”, then press \oplus .

To watch the channel, select “Allow”.

Intelligent Picture

“**On with Indicator**”*: Automatically reduces the picture noise. The signal level bar is displayed when the channel is changed or the display is changed from an input screen to a TV programme.

“**On**”*: Automatically reduces the picture noise.

“**Off**”*: Turns off the “Intelligent Picture” feature.

Manual Programme Preset

Before selecting “Label”/“AFT”/“Audio Filter”/“Skip”/“Colour System”/“Signal Booster”, press PROG +/- to select the programme number with the channel. You cannot select a programme number that is set to “Skip” (page 34).

Programme/TV System/VHF or UHF

Presets programme channels manually.

- 1 Select “Programme”, then press ⊕.
- 2 Press ⬆/⬇ to select the programme number you want to manually tune (if tuning a VCR, select channel 00), then press RETURN.
- 3 Press ⬆/⬇ to select “TV System”, then press ⊕.
- 4 Press ⬆/⬇ to select your TV broadcast systems, then press ⊕.
- 5 Press ⬆/⬇ to go to the frequency range indication (“VHF Low”, “VHF High” or “UHF”), then press ⊕.
- 6 Tune the channels as follows:

Press ⬅/➡ to search for the next available channel. When a channel has been found, the search will stop. To continue searching, press ⬅/➡.

Repeat the procedure above to preset other channels manually.

Label

Assigns a name of your choice, up to five letters or numbers, to the selected channel. This name will be displayed briefly on the screen when the channel is selected.

To input characters:

- 1 Press ⬆/⬇ to select the desired letter or number (“_” for a blank space), then press ➡.

If you input a wrong character

Press ⬅/➡ to select the wrong character. Then, press ⬆/⬇ to select the correct character.

- 2 Repeat the procedure in step 1 until the name is completed, then press ⊕.

AFT

Allows you to fine-tune the selected programme number manually if you feel that a slight tuning adjustment will improve the picture quality.

You can adjust the fine tuning over a range of -15 to +15. When “On” is selected, the fine tuning is performed automatically.

Audio Filter

Improves the sound for individual channels in the case of distortion in mono broadcasts. Sometimes a non-standard broadcast signal can cause sound distortion or intermittent sound muting when watching mono programmes.

If you do not experience any sound distortion, we recommend that you leave this option set to the factory setting “Off”.

🔊 • You cannot receive stereo or dual sound when “Low” or “High” is selected.

Skip

Skips unused channels when you press PROG +/- to select channels. (You can still select a skipped channel using the number buttons.)

Colour System

Selects the colour system (“Auto”, “PAL”, “SECAM”, “NTSC3.58”, “NTSC4.43” or “PAL60”) according to the channel.

Signal Booster (Intelligent Signal Booster)

Improves the picture quality if the TV signal is too strong or weak.







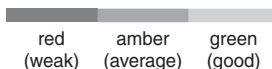



Press ⬆/⬇ to select either “Off” if the signal is too strong (picture distorted; picture with lines; signal interference) or “Auto” if the signal is weak (snowy picture), then press ⊕.

Signal Level

Displays the signal level for programme currently being watched.



Specifications

Model name	KLV-46V400A	KLV-40V400A	KLV-32V400A	
System				
Panel System	LCD (Liquid Crystal Display) Panel			
TV System	B/G, I, D/K, M			
Colour System	PAL, PAL60, SECAM, NTSC4.43, NTSC3.58			
Channel Coverage	B/G: VHF: E2 to E12/ UHF: E21 to E69/ CATV: S01 to S03, S1 to S41 I: UHF: B21 to B69/ CATV: S01 to S03, S1 to S41 D/K: VHF: C1 to C12, R1 to R12/ UHF: C13 to C57, R21 to R60/ CATV: S01 to S03, S1 to S41, Z1 to Z39 M: VHF: A2 to A13/ UHF: A14 to A79/ CATV: A-8 to A-2, A to W+4, W+6 to W+84			
Sound Output	10 W + 10 W			
Input/Output jacks				
Antenna	75 ohm external terminal			
 1	S video input (4-pin mini DIN)			
 1, 2, 3	Video input (phono jack)			
 1, 2, 3	Audio input (phono jacks): 500 mVrms, Impedance: 47 kilohms			
 1, 2	Supported formats: 1080p (50/60 Hz), 1080i (50/60 Hz), 720p (50/60 Hz), 576p, 576i, 480p, 480i Y: 1 Vp-p, 75 ohms, 0.3V sync negative/Pb/Cb: 0.7 Vp-p, 75 ohms/Pr/Cr: 0.7 Vp-p, 75 ohms			
 1, 2	Audio input (phono jacks): 500 mVrms, Impedance: 47 kilohms			
 →	Video output (phono jack)			
 →	Audio output (phono jacks)			
HDMI IN 1, 2, 3	Video: 1080/24p, 1080p (50/60 Hz), 1080i (50/60 Hz), 720p (50/60 Hz), 576p, 576i, 480p, 480i Audio: Two channel linear PCM 32, 44.1 and 48 kHz, 16, 20 and 24 bits Analogue audio input (minijack): 500 mVrms, Impedance: 47 kilohms (HDMI IN 3 only)			
PC IN  (RGB)	PC Input (D-sub 15-pin) (see page 32) G: 0.7 Vp-p, 75 ohms, non Sync on Green/B: 0.7 Vp-p, 75 ohms/ R: 0.7 Vp-p, 75 ohms/HD: 1-5 Vp-p/VD: 1-5 Vp-p			
PC IN 	PC audio input (minijack)			
	Audio output (phono jacks)			
	Headphones jack			
DMPORT	DIGITAL MEDIA PORT			
Power and others				
Power Requirements	110–240 V AC, 50/60 Hz			
Screen Size (inches)	46	40	32	
Display Resolution	1,920 pixels (horizontal) × 1,080 lines (vertical)		1,366 pixels (horizontal) × 768 lines (vertical)	
Power Consumption	Indicated on the rear of the TV.			
Dimensions (w × h × d)*	with stand (mm)	1120 × 782 × 307	986 × 684 × 279	794 × 577 × 242
	without stand (mm)	1120 × 742 × 115	986 × 646 × 110	794 × 540 × 99
Mass*	with stand (kg)	29	22	16
	without stand (kg)	25	19	13
Optional Accessories	Wall-Mount bracket	SU-WL500 and SU-WL50B		
	TV stand	SU-FL300M		

* Dimensions and mass are approximate values.

Design and specifications are subject to change without notice.



Troubleshooting

If you find any problem while viewing your TV, you can either check the Troubleshooting guide below or use the “Factory Settings” function (page 31). If the problem persists, contact your Sony dealer.

Check whether the  (standby) indicator is flashing in red.









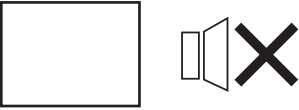

When it is flashing



The self-diagnosis function is activated.

- 1 Count how many  (standby) indicator flashes between each two second break.
For example, the indicator flashes three times, then there is a two second break, followed by another three flashes, etc.
- 2 Press  on the top edge of the TV to turn it off, disconnect the AC power cord, and inform your dealer or Sony service centre of how the indicator flashes (number of flashes).

When it is not flashing

- 1 Check the items listed below.
- 2 If the problem still persists, have your TV serviced by qualified service personnel.

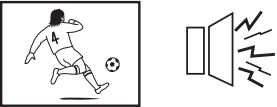
Problem	Cause/Remedy
No Picture	
No picture (screen is dark) and no sound 	<ul style="list-style-type: none"> • Check the antenna/cable connection. • Connect the TV to the AC power outlet, and press  on the top edge of the TV. • If the  (standby) indicator lights up in red, press .
No picture or no menu information from equipment connected to the video input jack	<ul style="list-style-type: none"> • Press / to display the connected equipment list, then select the desired input. • Check the connection between the optional equipment and the TV.
Poor Picture	
Only snow and noise appear on the screen  	<ul style="list-style-type: none"> • Check if the antenna is broken or bent. • Check if the antenna has reached the end of its serviceable life (three to five years in normal use, one to two years at the seaside).
Distorted picture (dotted lines or stripes)  	<ul style="list-style-type: none"> • Keep the TV away from electrical noise sources such as cars, motorcycles, hair-dryers or optional equipment. • When installing optional equipment, leave some space between the optional equipment and the TV. • Check the antenna/cable connection. • Keep the antenna cable away from other connecting cables. • Broadcast signals are too strong. Set the “Signal Booster” to “Off” (page 34) or turn off or disconnect the booster if it is in use.
Picture or sound noise when viewing a TV channel	<ul style="list-style-type: none"> • Select “Manual Programme Preset” in the “Channel Set-up” menu and adjust “AFT” (Automatic Fine Tuning) to obtain better picture reception (page 34). • Select “Noise Reduction” in the “Picture” menu to reduce the noise in the picture (page 26).

Problem	Cause/Remedy
Good picture, but noisy sound 	<ul style="list-style-type: none"> • The TV system setting is inappropriate. • If the sound of all the channels are noisy, perform “Auto Tuning” in the “Channel Set-up” menu to preset the channel again (page 33). • If the sound of some channels is noisy, select the channel, then perform “Manual Programme Preset” in the “Channel Set-up” menu, and select the appropriate TV system (“TV System”) (page 34).
Some tiny black points and/or bright points appear on the screen	<ul style="list-style-type: none"> • The picture of a display unit is composed of pixels. Tiny black points and/or bright points (pixels) on the screen do not indicate a malfunction.
No colour on programmes 	<ul style="list-style-type: none"> • Select “Reset” in the “Picture” menu to return to the factory settings (page 26).
No colour or irregular colour when viewing a signal from the Y, Pb/Cb, Pr/Cr jacks of ①/② 1 or 2	<ul style="list-style-type: none"> • Check the connection of the Y, Pb/Cb, Pr/Cr jacks of ①/② 1 or 2. • Make sure that the Y, Pb/Cb, Pr/Cr jacks of ①/② 1 or 2 are firmly seated in their respective jacks.
Picture flashes initially when changing to HDMI mode or switching on the TV with HDMI mode	<ul style="list-style-type: none"> • This is probably caused by the authentication process between HDMI equipment and the TV. It does not indicate a malfunction.
Sound	
No sound, but good picture 	<ul style="list-style-type: none"> • Press \triangle +/- or \times (Mute). • Check if the “Speaker” is set to “TV Speaker” from the “AV Set-up” menu in “Set-up” menu (page 30).
Stereo broadcast sound switches on and off, or is distorted; the sound switches between stereo and monaural frequently	<ul style="list-style-type: none"> • The antenna connection is loose or the antenna cable is damaged. Check the cable and connection on the TV, VCR, and on the wall (page 5). • Adjust the antenna direction for the minimum interference. Contact a Sony dealer for advice. • Signal transmission is low. Try using a booster. Otherwise, use the fine tuning (“AFT”) function (page 34).
General	
The TV turns off automatically (the TV enters standby mode)	<ul style="list-style-type: none"> • Check if the “Sleep Timer” is activated, or confirm the “Duration” setting of “On Timer” (page 31).
The TV turns on automatically	<ul style="list-style-type: none"> • Check if the “On Timer” is activated (page 31).
Some input sources cannot be selected	<ul style="list-style-type: none"> • Select “Video Labels” in the “AV Set-up” menu and cancel “Skip” of the input source (page 29).
The remote does not function	<ul style="list-style-type: none"> • Replace the batteries.
The “Store Display Mode: On” message appears on the screen	<ul style="list-style-type: none"> • Select “Factory Settings” in the “Set-up” menu (page 31).

Problem	Cause/Remedy
The wide screen mode changes spontaneously when “Auto Wide” is “On”	<ul style="list-style-type: none"> • During a transition between two programmes, the TV detects the optimum wide screen mode. During this period, an irregular wide screen mode may appear. • The wide mode is switched automatically according to the revised signal with a Wide ID signal. • The “Auto Wide” feature stops working temporarily when you press ⏏, and resumes after a while. To fix in the manually selected wide screen mode, set “Auto Wide” to “Off” in the “Screen” menu (page 28).
Text display is incomplete or garbled	<ul style="list-style-type: none"> • Your area may not be able to receive Text. Text is displayed only in the area that is covered by Text services. • The antenna connection is loose or the antenna cable is damaged. Check the cable and connection on the TV, VCR, and on the wall (page 5). • Adjust the antenna direction. Contact a Sony dealer for advice. • Signal transmission is too low. Try using a booster. • Using the fine tuning (“AFT”) function may improve the picture (page 34).
Cannot play shooting games	<ul style="list-style-type: none"> • Some shooting games which involve pointing a light beam at the TV screen with an electronic gun or rifle cannot be used with your TV. For details, see the instruction manual supplied with the video game software.
The TV cabinet creaks	<ul style="list-style-type: none"> • Changes in room temperature sometimes make the TV cabinet expand or contract, causing a noise. This does not indicate a malfunction.
Static discharge is felt when touching the TV cabinet	<ul style="list-style-type: none"> • This is the same static discharge that is felt when touching metal door handles or car doors especially when the air is dry, for example in winter. This does not indicate a malfunction.
Weak signal (signal level indicator displayed in red)	<ul style="list-style-type: none"> • Check the antenna/cable connection. • Set the “Signal Booster” to “Auto” (page 34) or try using an external booster.
Sound does not match pictures on the screen when audio is output directly from the amplifier system	<ul style="list-style-type: none"> • Adjust the sound delay settings from the connected equipment to minimize the time gap between the audio and video output.



Customer support

<http://www.sony-asia.com/support>



Printed on 70% or more recycled paper using
VOC (Volatile Organic Compound)-free
vegetable oil based ink.



* 3 3 0 0 8 8 7 1 2 * (1)

<http://www.sony.net/>

Printed in Malaysia

SONY®

KDL-46D3100 KLV-37S400A
KDL-46V3100 KLV-37S310A
KLV-46D300A KDL-32D3100
KLV-46V400A KDL-32S3100
KDL-40D3100 KDL-32V3100
KDL-40V3100 KLV-32D300A
KLV-40D300A KLV-32S400A
KLV-40S400A KLV-32S310A
KLV-40S310A KLV-32V400A
KLV-40V400A KLV-32V400B
KDL-37S3100

Installing the Wall-Mount Bracket

GB

安裝掛壁式支架

CT

تثبيت السناد الخاص بتركيب التلفزيون على الجدار

AR

نصب کردن دیوار کوب

PR



* 3 2 1 4 1 2 8 1 4 * (1)

To Customers:

For product protection and safety reasons, Sony strongly recommends that installing of your TV be performed by Sony dealers or licensed contractors. Do not attempt to install it yourself.

Your KDL-46D3100/KDL-46V3100/KLV-46D300A/KLV-46V400A/KDL-40D3100/KDL-40V3100/KLV-40D300A/KLV-40S400A/KLV-40S310A/KLV-40V400A/KDL-37S3100/KLV-37S400A/KLV-37S310A/KDL-32D3100/KDL-32S3100/KDL-32V3100/KLV-32D300A/KLV-32S400A/KLV-32S310A/KLV-32V400A/KLV-32V400B can be installed using SU-WL500 Wall-Mount Bracket (sold separately). Please provide your licensed contractor with this installation supplement as well as the Instructions (supplied with the SU-WL500 Wall-Mount Bracket). Read these documents carefully for safety and proper installation.

To Sony Dealers and Contractors:

Provide full attention to safety during the installation, periodic maintenance and examination of this product.

Installing the TV

The TV can be installed on a wall by attaching a Wall-Mount Bracket (sold separately).

Verify your TV's model number and be sure to use the bracket specified for your model only. Refer to the steps on this manual along with the Instructions supplied with the SU-WL500 Wall-Mount Bracket, to properly carry out the installation.

Sufficient expertise is required for installing this product, especially to determine the strength of the wall for withstanding the TV's weight. Be sure to entrust the attachment of this product to the wall to Sony dealers or licensed contractors and pay adequate attention to safety during the installation. Sony is not liable for any damage or injury caused by mishandling or improper installation.

Step 1: Checking the parts required for the installation

Open the Wall-Mount Bracket package and check the contents for all required parts along with the Instructions.

Step 2: Deciding on the installation location

Decide where you want to install your TV. Refer to the last 2 pages of this manual for the TV installation dimensions and determine the location.

Refer to the Instructions for the SU-WL500.

Step 3: Installing the Base Bracket on the wall

Refer to the Instructions for the SU-WL500.

Step 4: Preparing for the installation of the TV

Before detaching the Table-Top Stand, disconnect all the cables from the TV.

1 Remove the screws from the rear of the TV. Then detach the Table-Top Stand from the TV.

► For KDL-46D3100/KDL-46V3100/KLV-46D300A/
KDL-40D3100/KDL-40V3100/KLV-40D300A/
KLV-40S310A/KDL-37S3100/KLV-37S310A

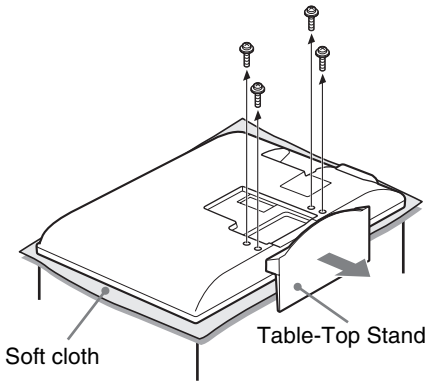

► For KLV-46V400A/KLV-40V400A

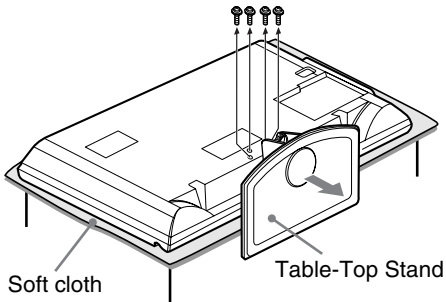

► For KDL-32D3100/KDL-32S3100/KDL-32V3100/
KLV-32D300A/KLV-32S310A

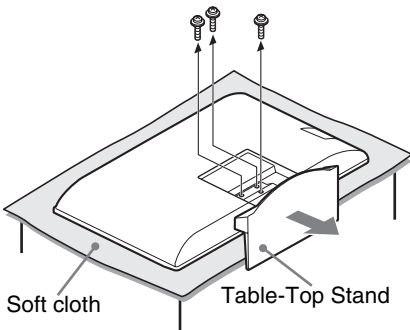

► For KLV-40S400A/KLV-37S400A/KLV-32S400A/
KLV-32V400A/KLV-32V400B

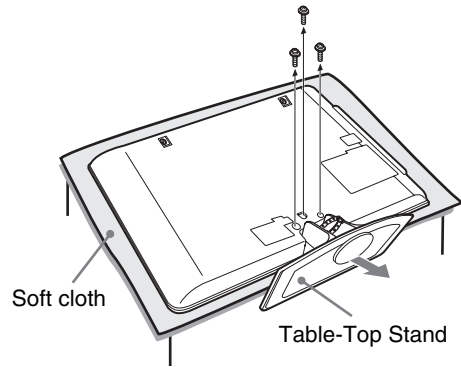

Do not remove any other screws from the TV.

Notes

- When removing the Table-Top Stand from the TV, lay the display face down on a stable work surface that is larger than the TV.
- To prevent damaging the surface of the LCD display, make sure to place a soft cloth on the work surface.

GB

2 Referring to the Screw and Hook locations diagram/table on last page, determine the screw positions, and secure the Mounting Hook to the rear of the TV.

- 1 Secure the Mounting Hook to the rear of the TV temporarily, using the supplied four screws (+PSW6 × 16).
- 2 Be sure that both screws are securely tightened with equal torque strength to the rear of the TV.

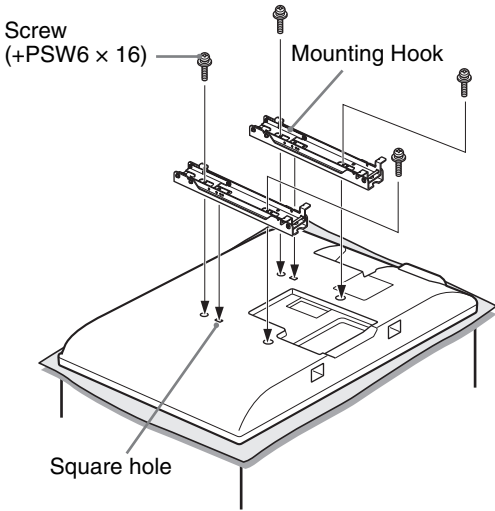

Align the tab on the rear of the Mounting Hook with the square hole on the rear of the TV as in the illustration below.

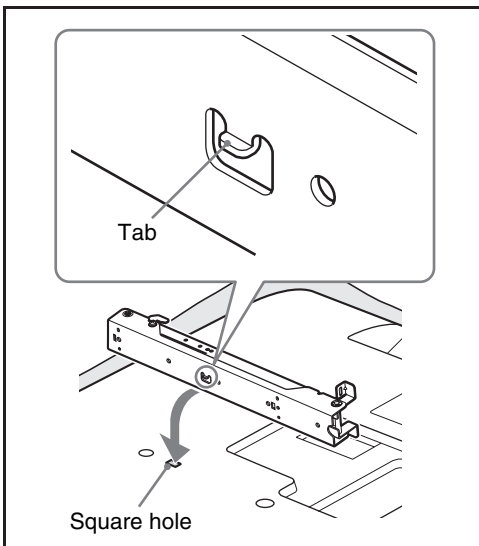

Note

Be sure not to use any screws other than the supplied ones (+PSW6 × 16) when securing the Mounting Hook.

3 Adjust the angle of the Mounting Hook using the supplied hexagon wrench.

When installing the TV parallel to the wall (0 degrees), adjustment of the Mounting Hook angle (procedures 1 and 2 below) is not necessary. Make sure that each arm base (X) is screwed in securely.

- 1 Remove the two screws from the arm base (X) of the Mounting Hook. Choose the holes corresponding to the desired angle (5, 10, 15 or 20 degrees).
- 2 Adjust the angles of the top (Y) and bottom (Z) arm to fit the corresponding hole, and firmly secure each arm using the two screws removed in the previous procedure 1.

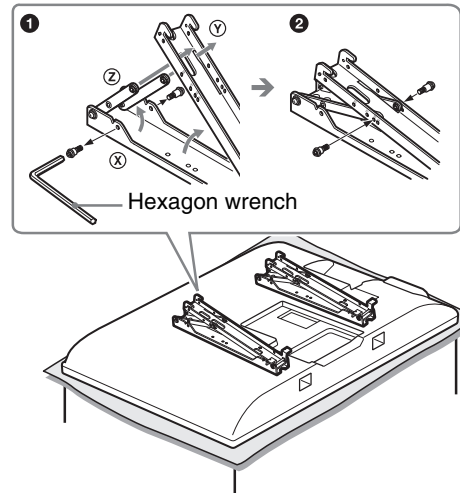

Notes

- Be sure to adjust the right and left arms to the same angle.
- Make sure that the two arm bases are screwed in securely.

CAUTION

Be careful not to pinch your fingers when adjusting the angle of the Mounting Hook.

Step 5: Installing the TV on the wall

Refer to the Instructions for the SU-WL500.

Notes

- When you put the TV back on the stand, reverse the above steps (insert the posts of the stand, aligning with the lines on the rear of the TV).
- When moving the TV, do not squeeze the bottom of the front panel too strongly.
- Remove the screws or install the Mounting Hook on a stable and level surface.

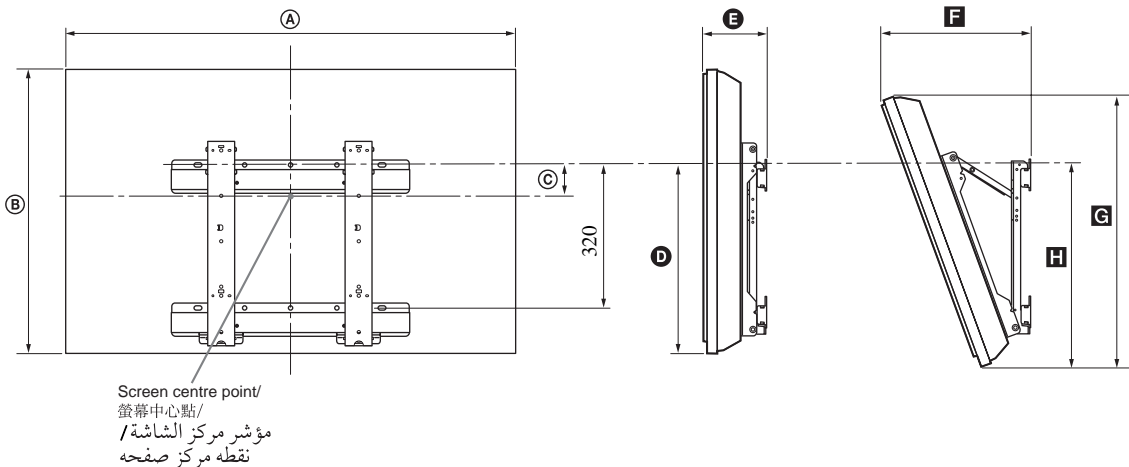

English Installation dimensions table *

AR جدول أبعاد التركيب *

中文 安裝尺寸表 *

PR جدول ابعاد نصب *

Unit: mm
單位: mm
الوحدة: مم
واحد: ميلي متر

Model Name/ 型號/ إسم الموديل/ نام مدل	Display dimensions/ 電視機尺寸/ أبعاد التلفزيون/ إبعاد صفحه نمایش		Screen centre dimension/ 螢幕中心尺寸/ حجم مركز الشاشة/ إبعاد مركز صفحه	Length for each mounting angle/ 不同安裝角度時的長度 / طول كل زاوية للتثبيت/ طول برای هر زاویه ای از سوار کردن				
	A	B	C	Angle (0°)/ 角度 (0°)/ زاوية (0 درجة)/ زاوية (0 درجه)		Angle (20°)/ 角度 (20°)/ زاوية (20 درجة)/ زاوية (20 درجه)		
				D	E	F	G	H
KLV-46V400A	1120	742	84	487	175	384	704	521
KLV-46D300A/KDL-46D3100/ KDL-46V3100	1114	730	106	505	175	373	705	545
KLV-40S400A	997	644	122	465	170	354	619	507
KLV-40V400A	986	646	122	474	170	351	614	507
KLV-40D300A/KDL-40D3100/ KDL-40V3100	981	643	157	505	170	338	622	543
KLV-40S310A	981	643	157	505	171	340	623	544
KLV-37S400A	931	609	139	464	170	342	586	506
KLV-37S310A/KDL-37S3100	920	626	157	505	175	337	609	545
KLV-32S400A	809	542	172	464	159	309	523	503
KLV-32V400A/KLV-32V400B	794	540	172	470	159	306	518	499
KLV-32D300A/KDL-32D3100/ KDL-32V3100	790	530	137	424	160	318	516	464
KLV-32S310A/KDL-32S3100	790	530	137	424	165	323	516	465

* Installation dimensions may differ according to how the TV is installed.

* 安裝尺寸視如何安裝電視機而異。

* تختلف أبعاد التركيب بكيفية تركيب التلفزيون.

* ابعاد نصب ممكن است مطابق با چگونگی نصب تلویزیون متفاوت باشند.

Screw location

螺絲位置
مكان البرغي
محل بيچ

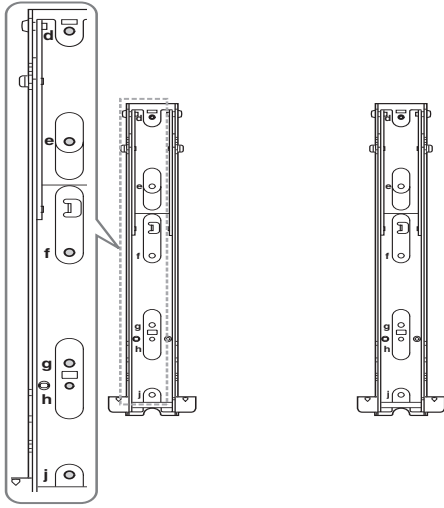

Hook location

掛鈎位置
مكان الخطاف
محل قلاب

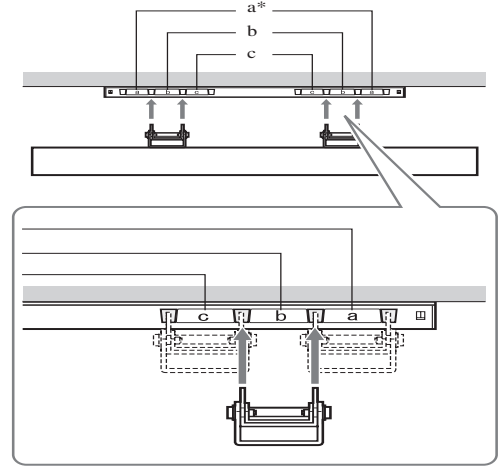

* Hook position "a" cannot be used for the models in the table below.

* 懸掛鈎位置 "a" 不能用於下表中的機型。

* لا يمكن استعمال موقع الخطاف "a" للموديلات المدرجة في الجدول أدناه.

* موقعيت قلاب "a" برای مدلهاى جدول زیر نمی تواند استفاده شود.

Model Name / 型號 / اسم الموديل / نام مدل	Screw location / 螺絲位置 / مكان البرغي / محل بيچ	Hook location / 掛鈎位置 / مكان الخطاف / محل قلاب
KLV-46V400A	d, g	b
KLV-46D300A/KDL-46D3100/KDL-46V3100	e, g	b
KLV-40S400A/KLV-40V400A	d, g	b
KLV-40D300A/KDL-40D3100/KDL-40V3100/KLV-40S310A	e, g	b
KLV-37S400A	d, g	b
KLV-37S310A/KDL-37S3100	e, g	b
KLV-32S400A/KLV-32V400A/KLV-32V400B	e, g	c
KLV-32D300A/KDL-32D3100/KDL-32V3100/KLV-32S310A/KDL-32S3100	f, j	c



Printed on 70% or more recycled paper using
VOC (Volatile Organic Compound)-free
vegetable oil based ink.

<http://www.sony.net/>

Printed in Malaysia